

# Barton Creek Residence

Austin TX

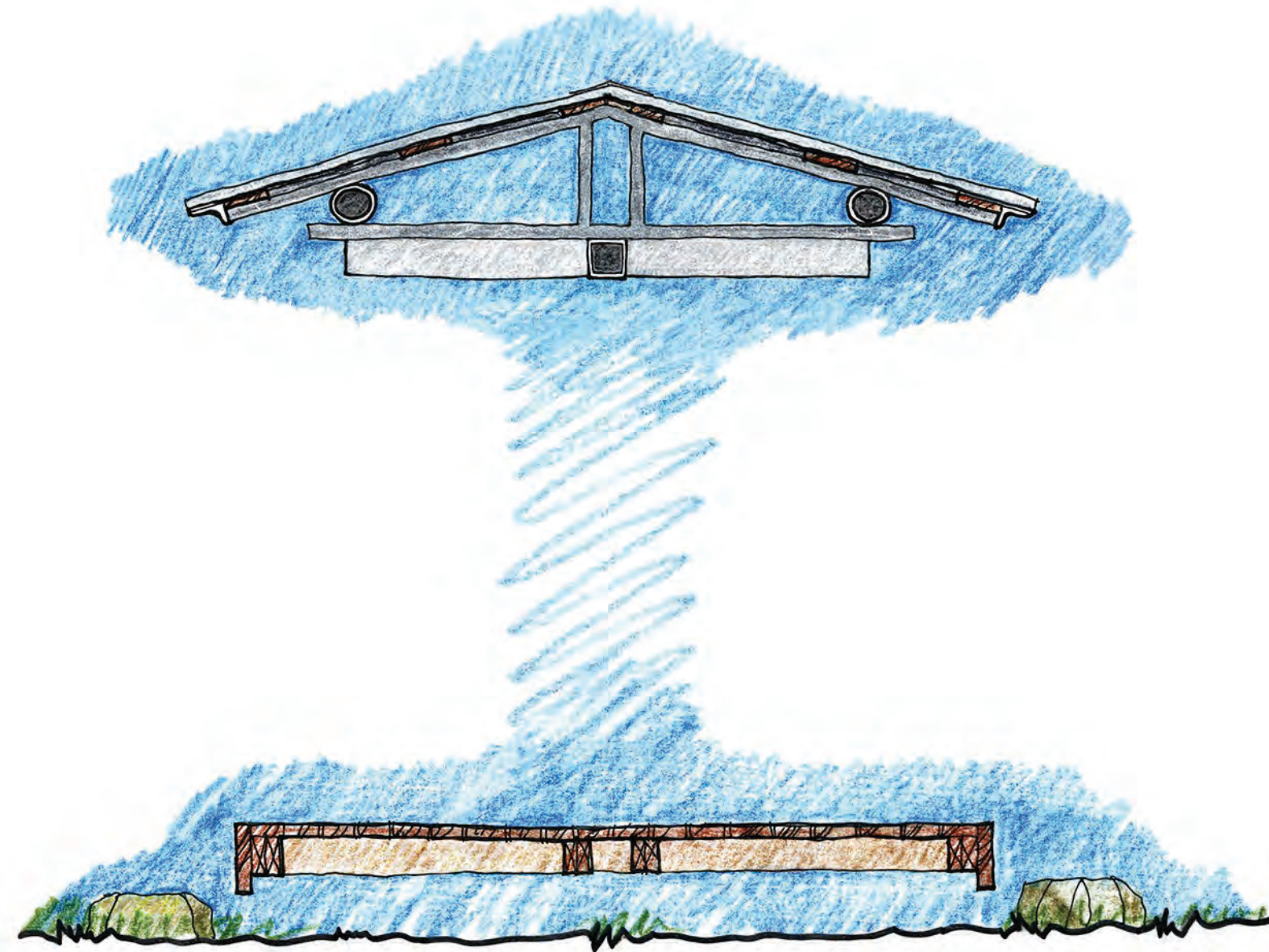

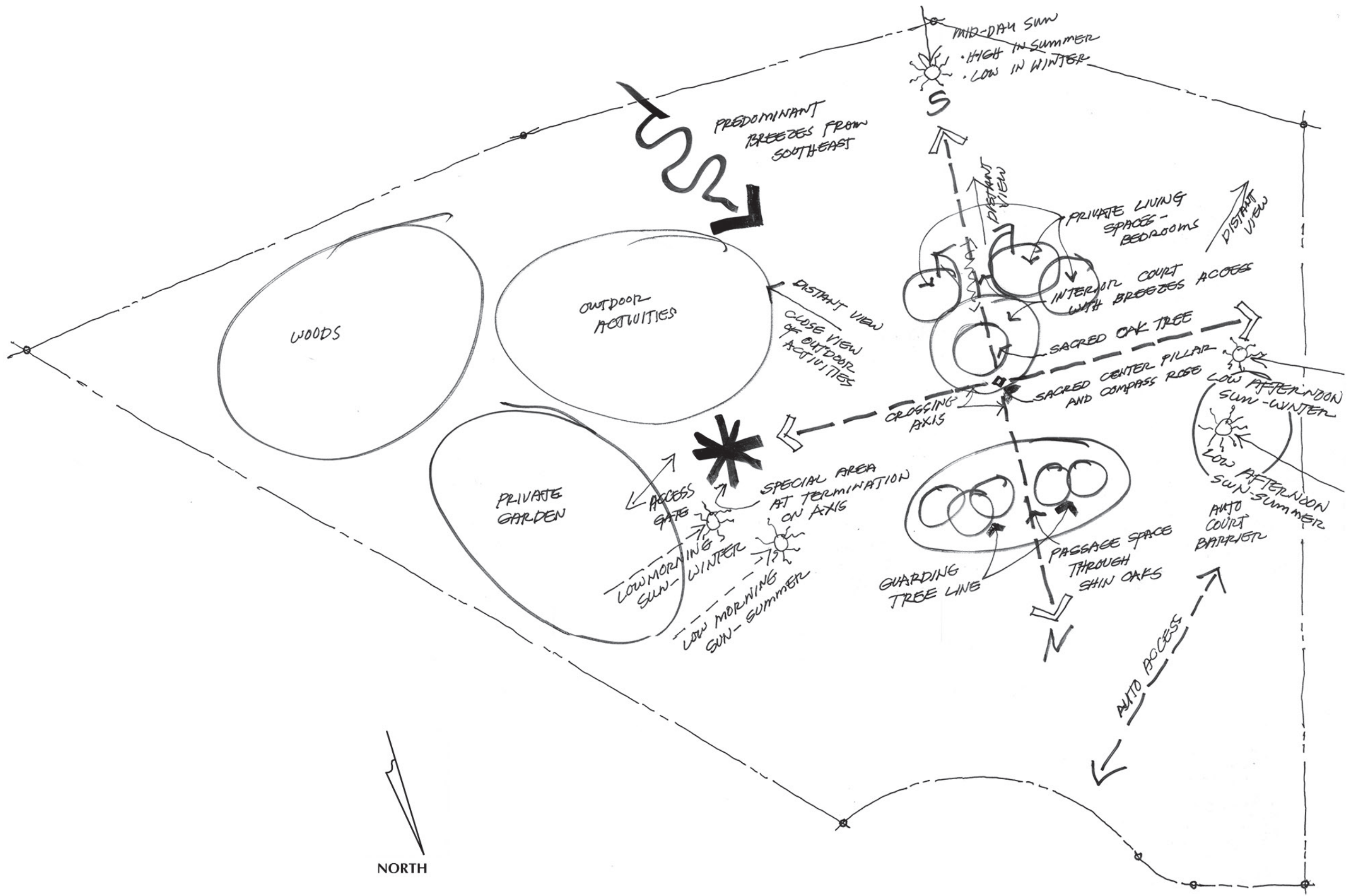

NIX GROUP ARCHITECTS



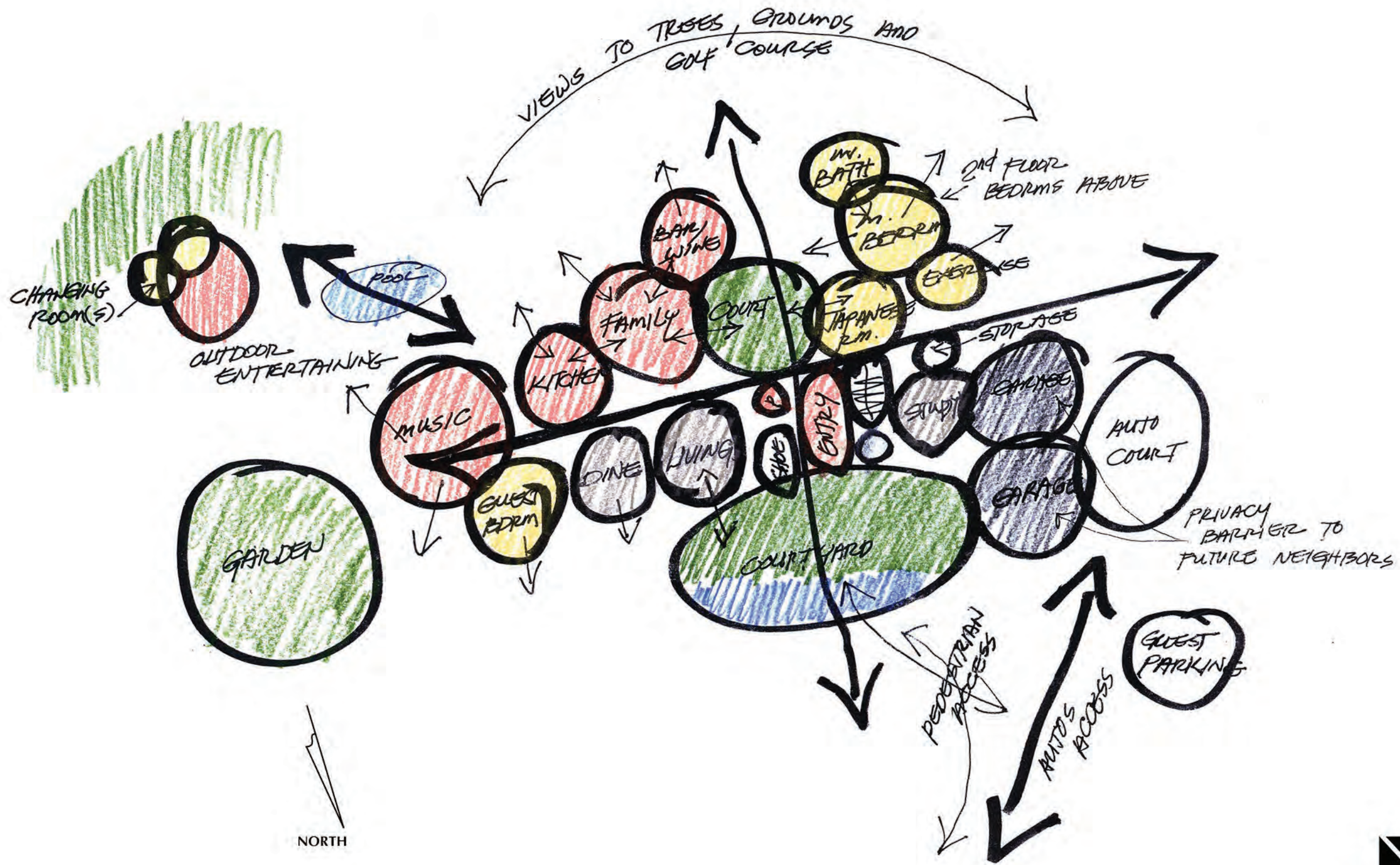



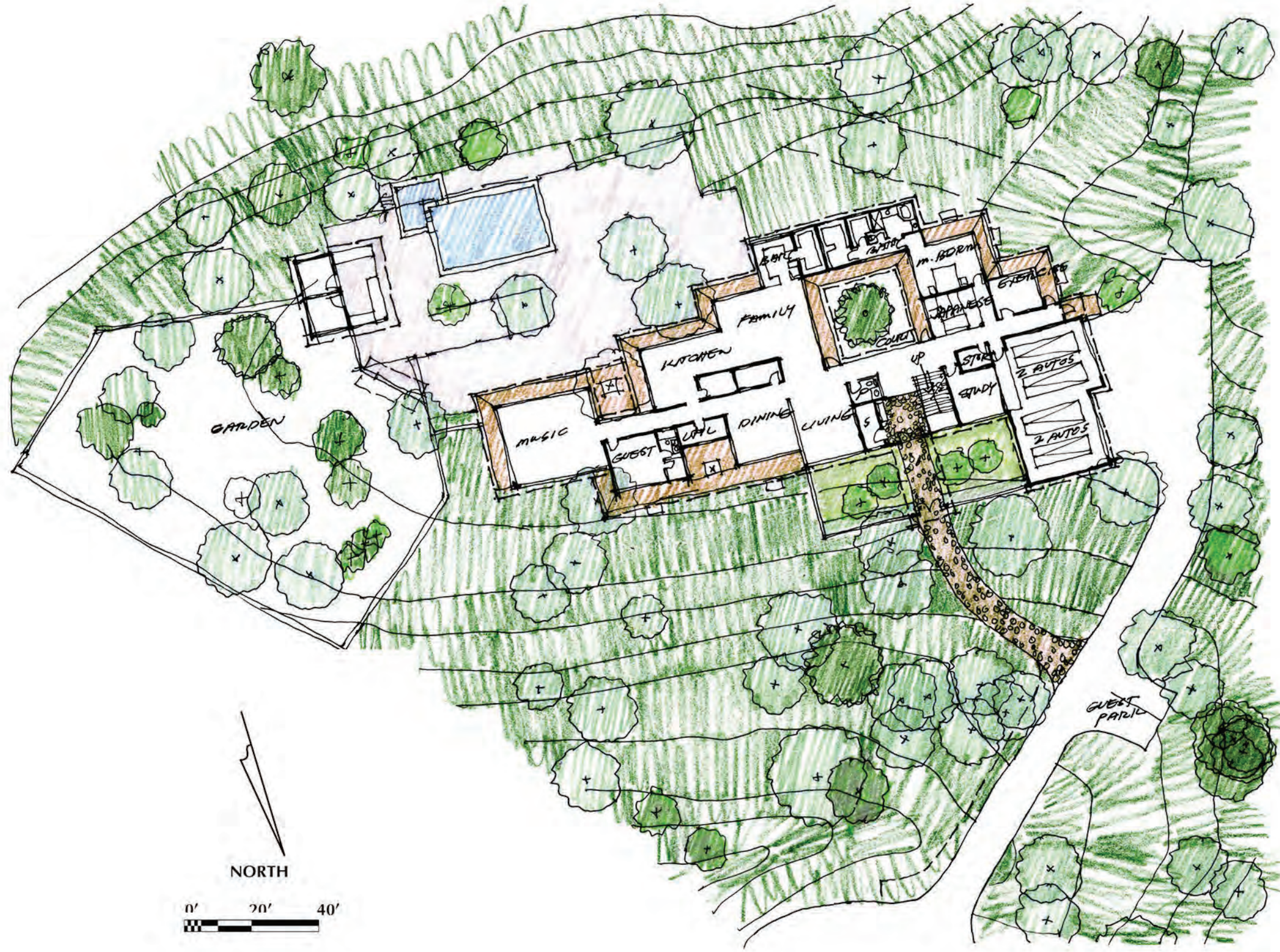

NIX GROUP  
ARCHITECTS



BARTON CREEK RESORT  
AND CLUB

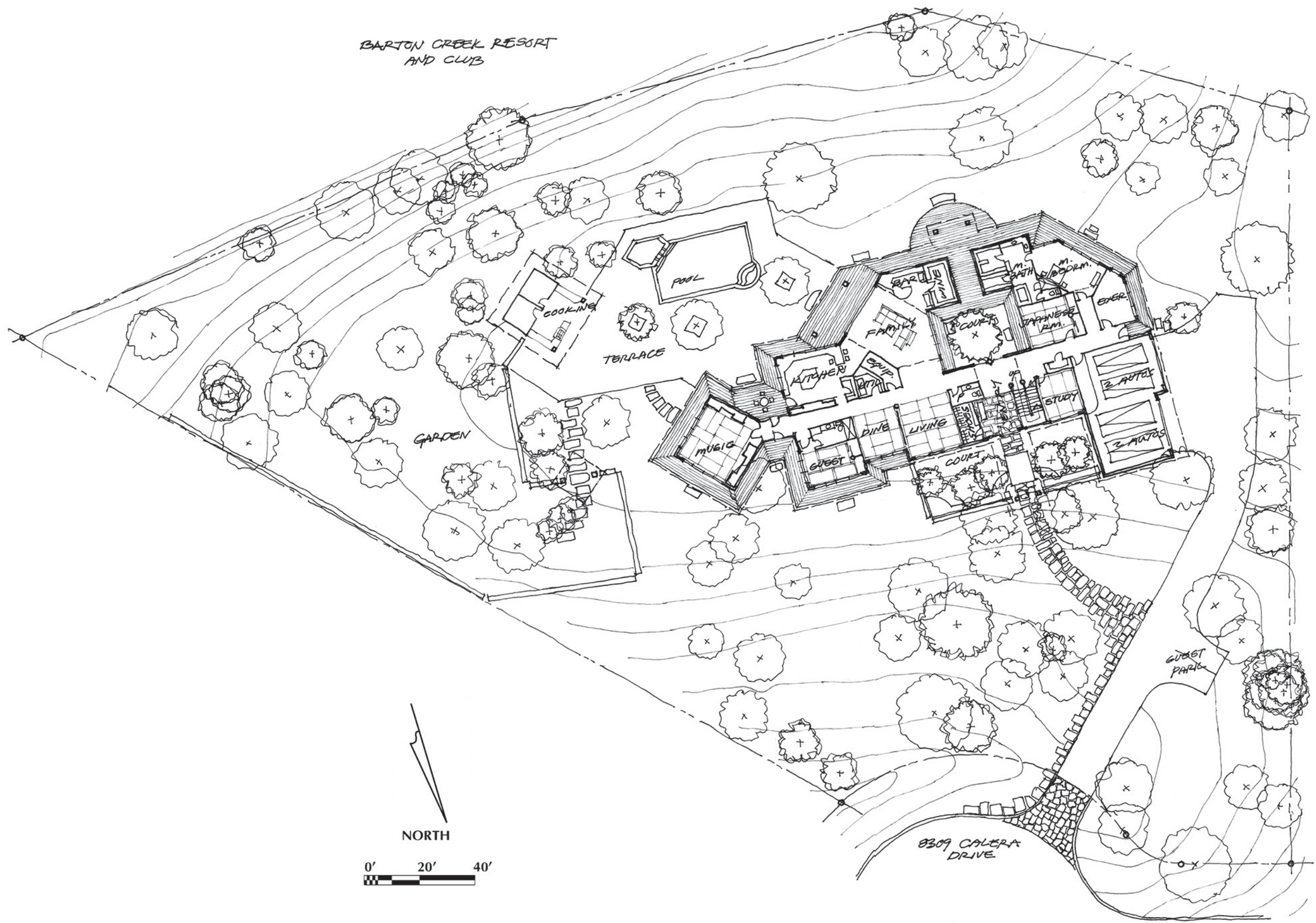



BARTON CREEK RESORT  
AND CLUB

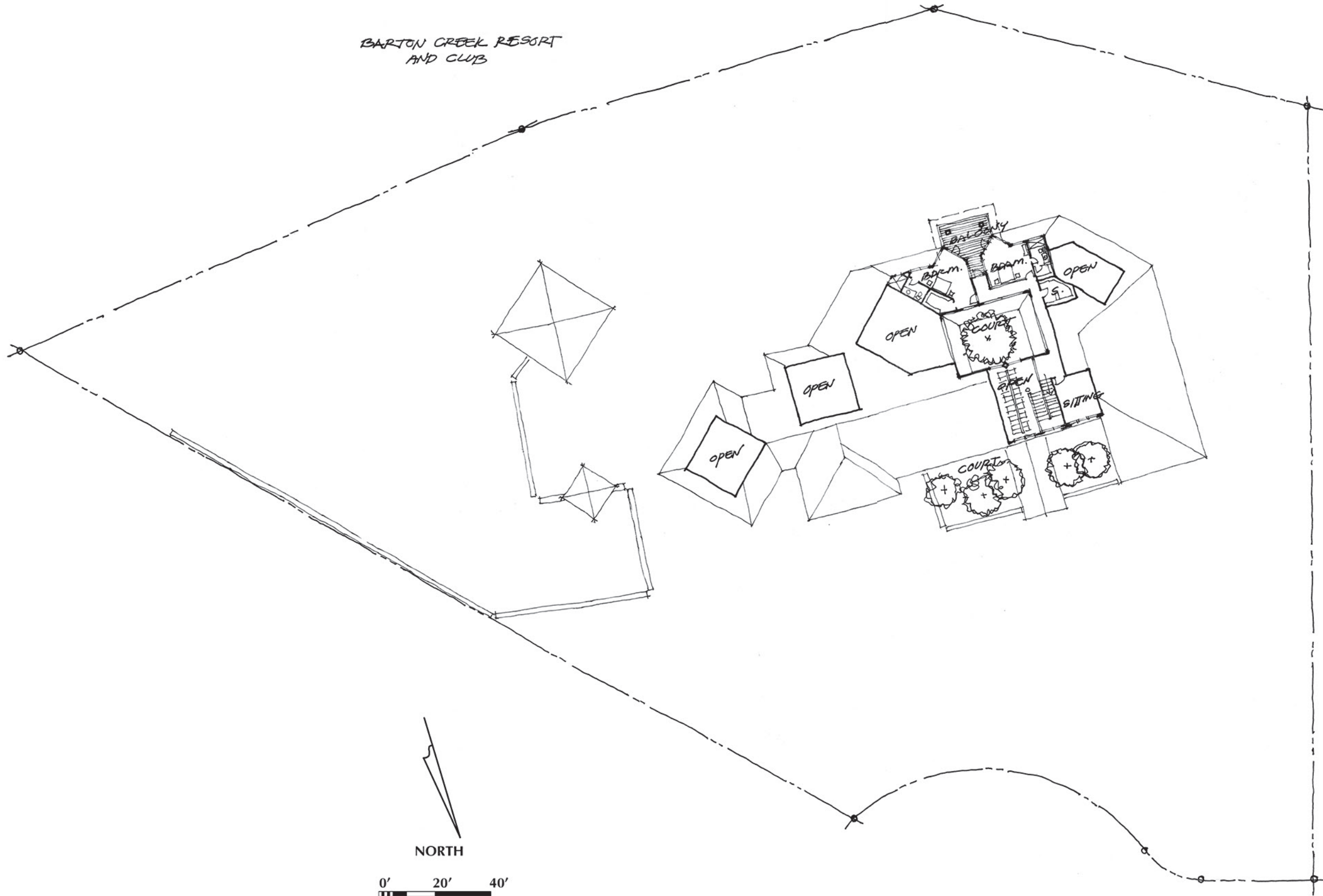



BARTON CREEK RESORT  
AND CLUB

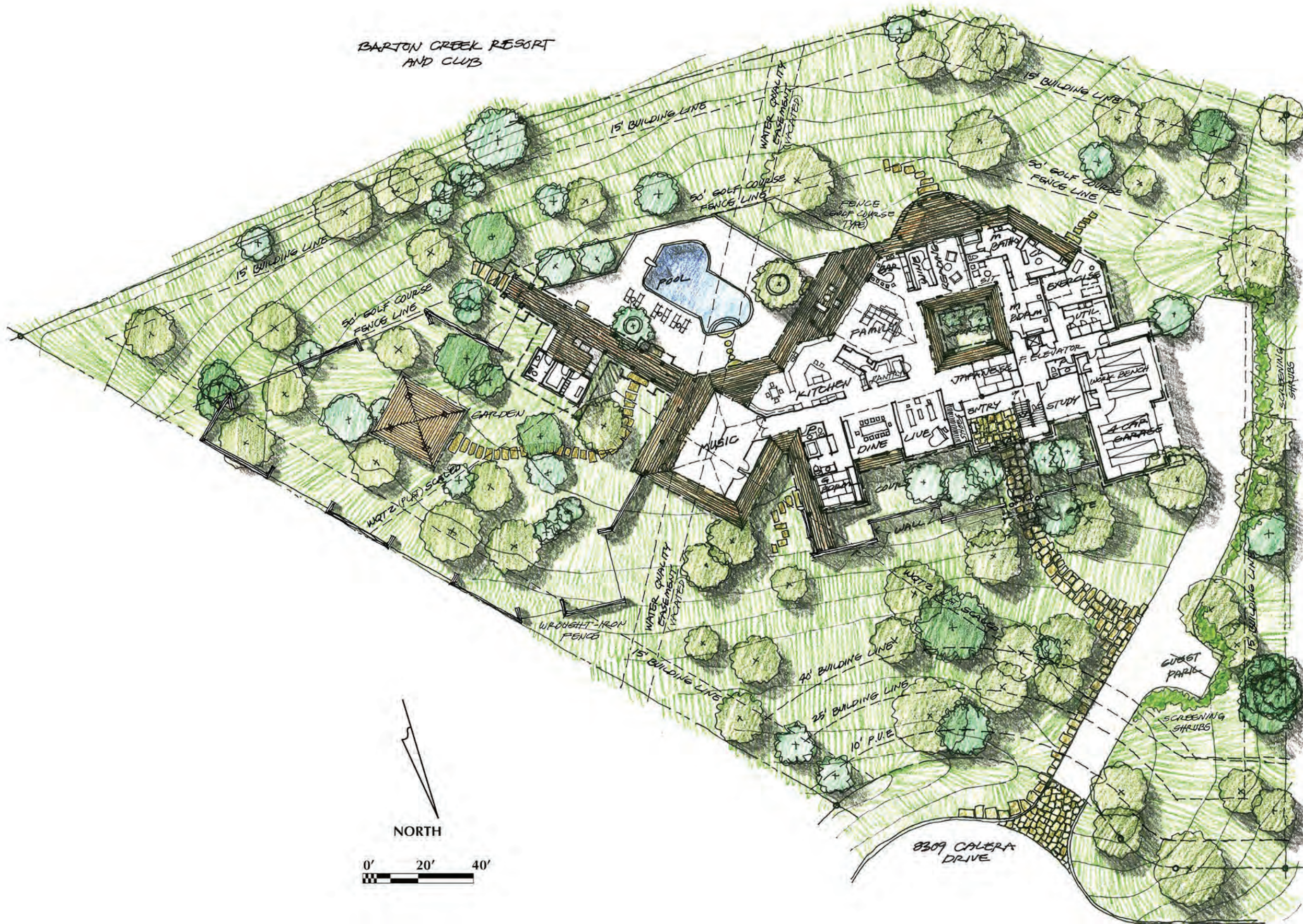



BARTON CREEK RESORT  
AND CLUB

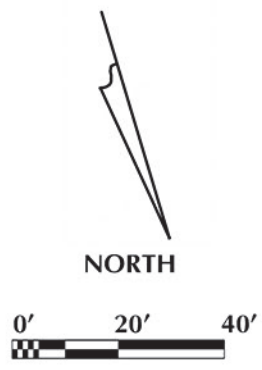
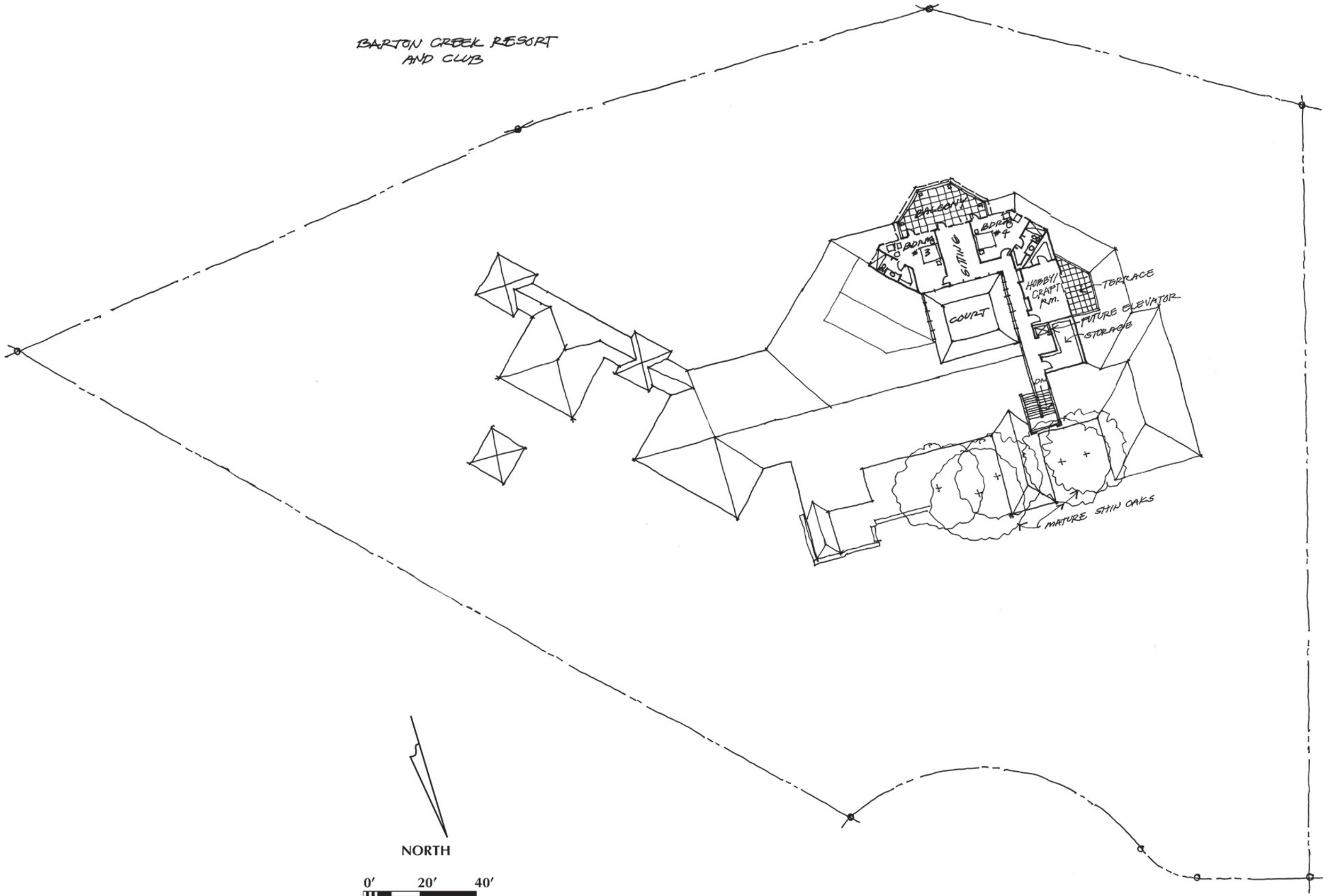



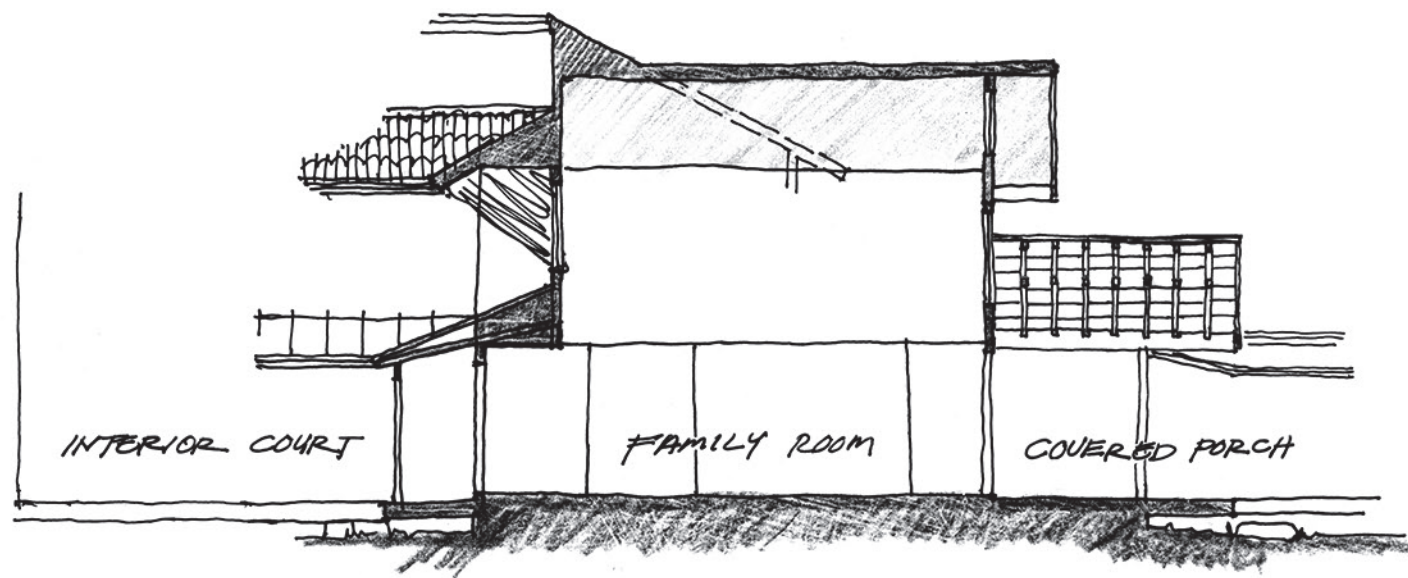

SECTION #4

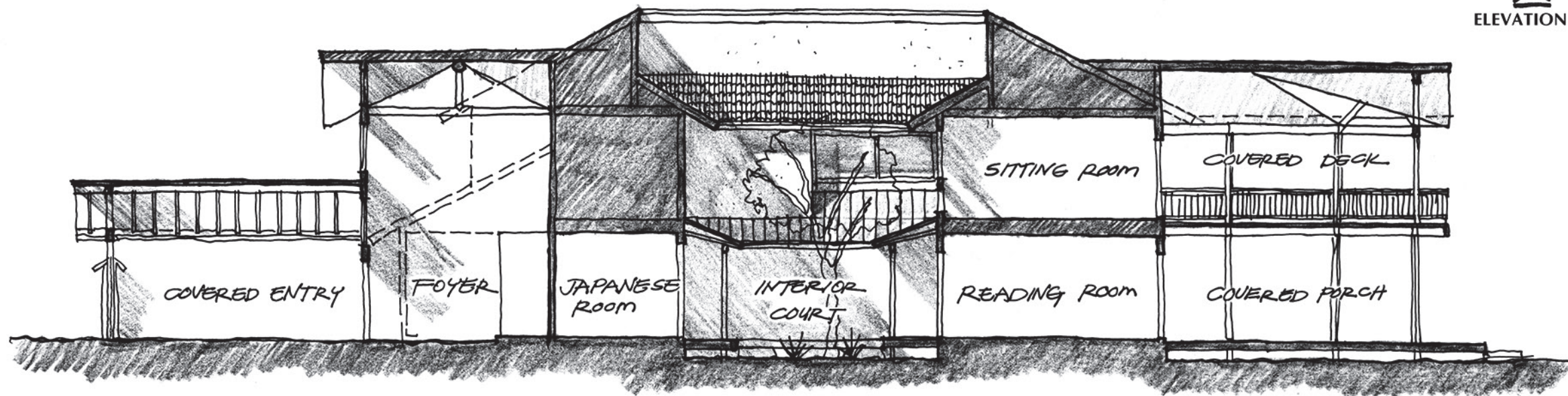
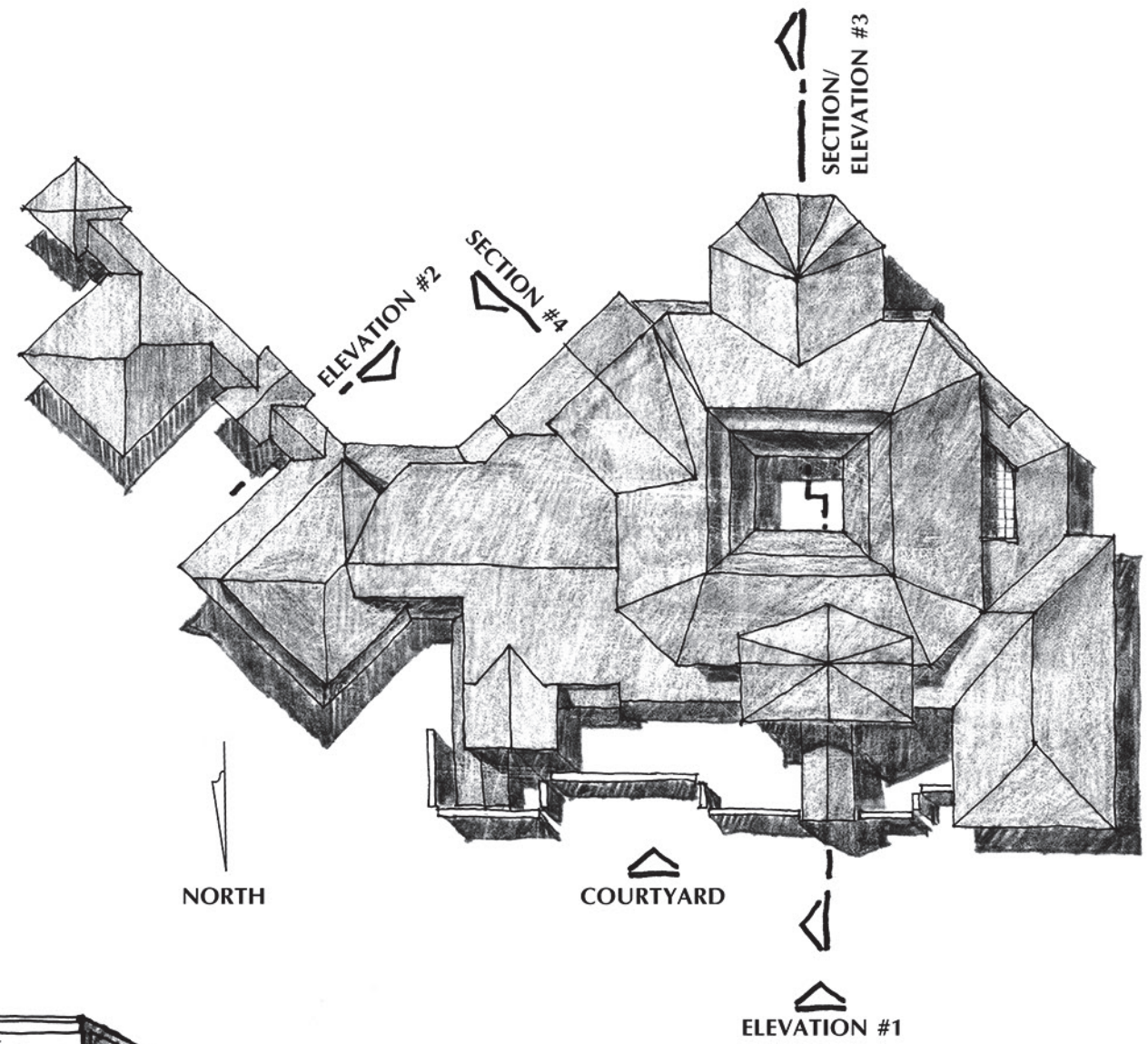

SECTION/ ELEVATION- #3



NIX GROUP  
ARCHITECTS



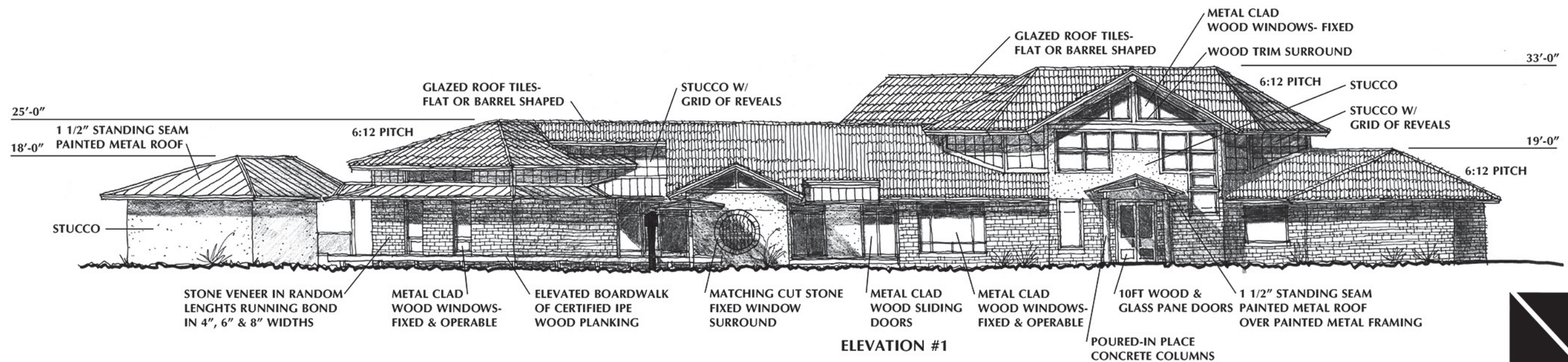
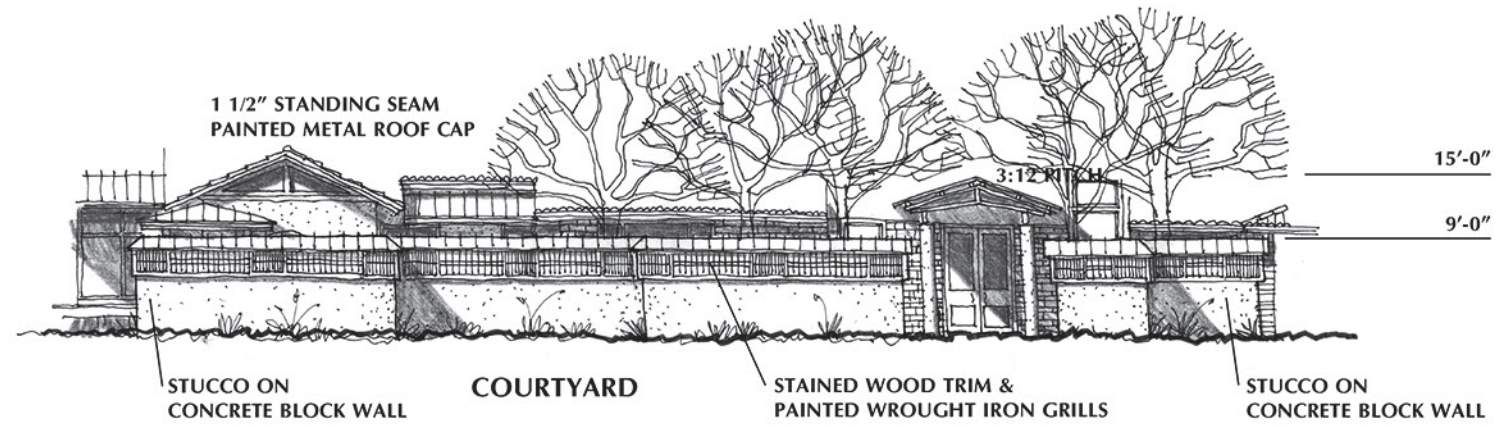
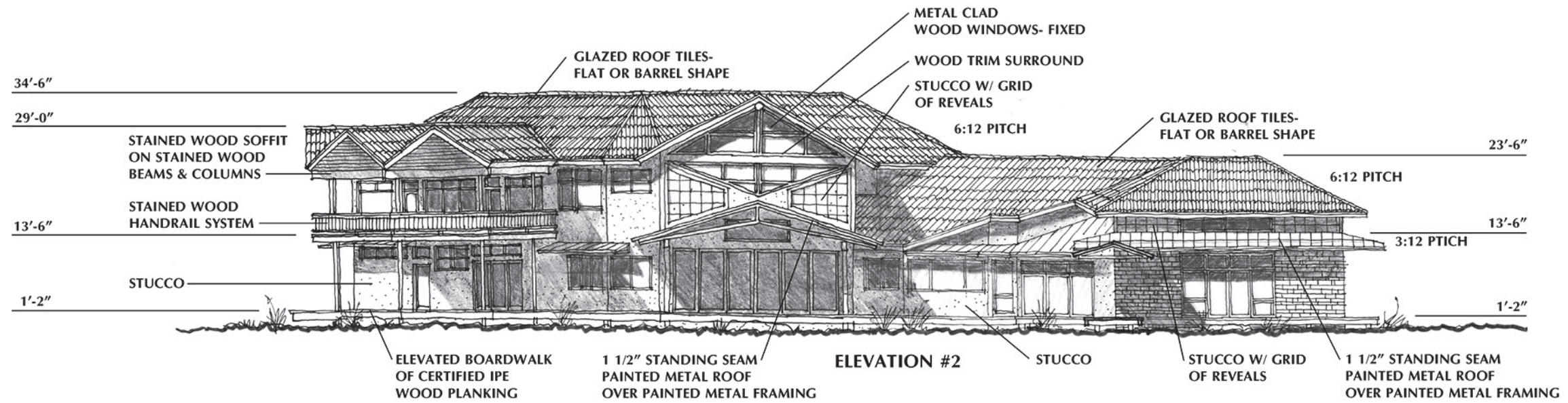



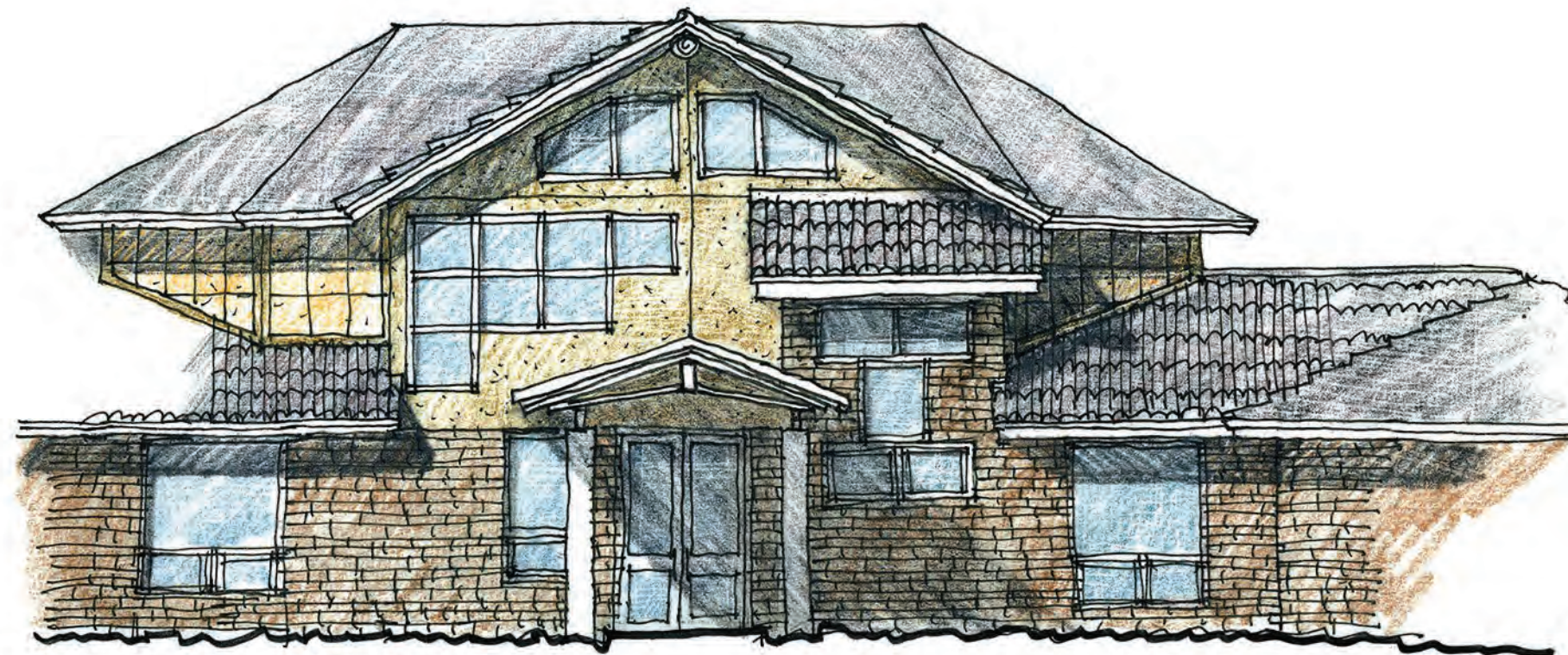





NIX GROUP  
ARCHITECTS



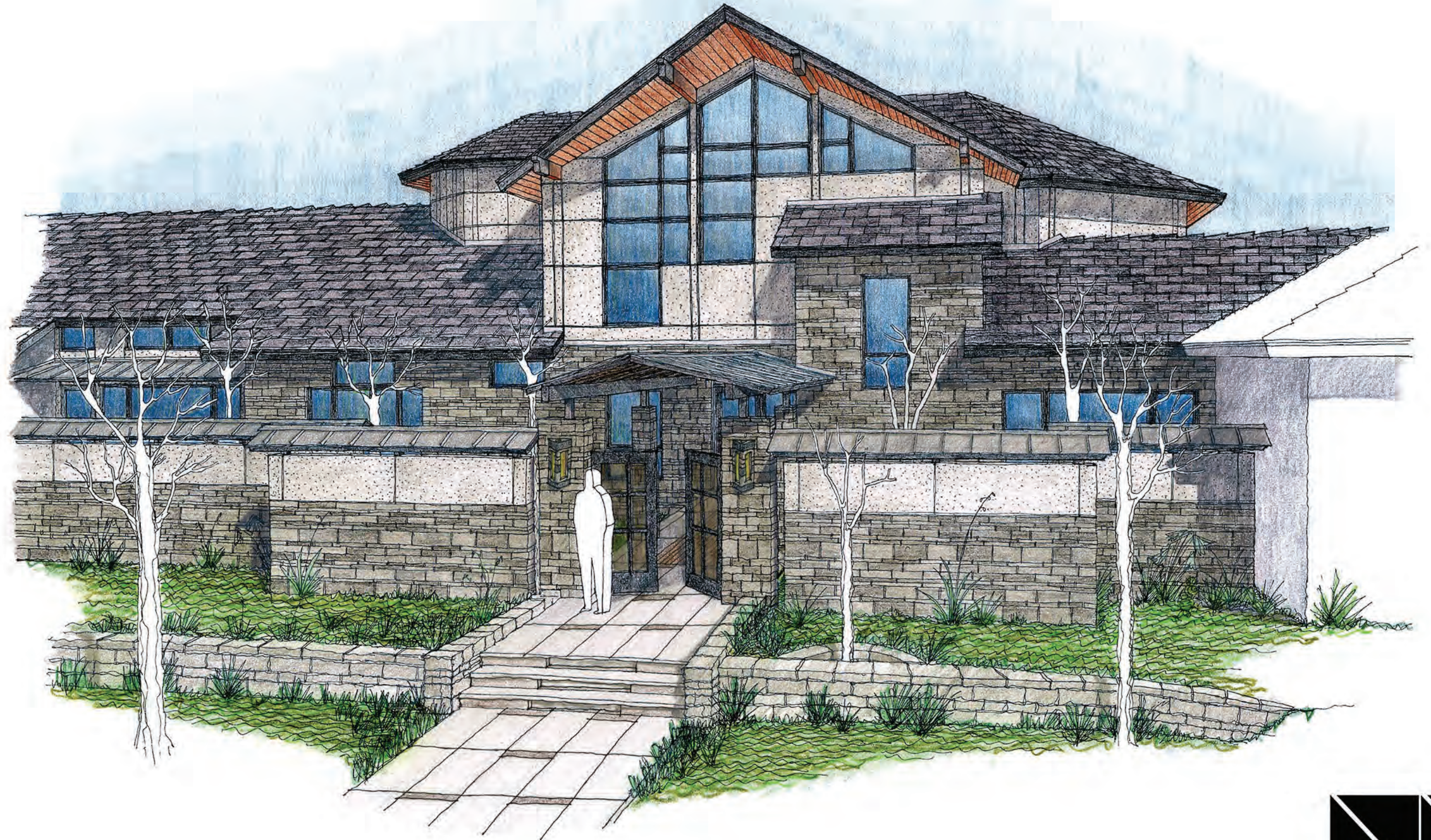

NIX GROUP  
ARCHITECTS



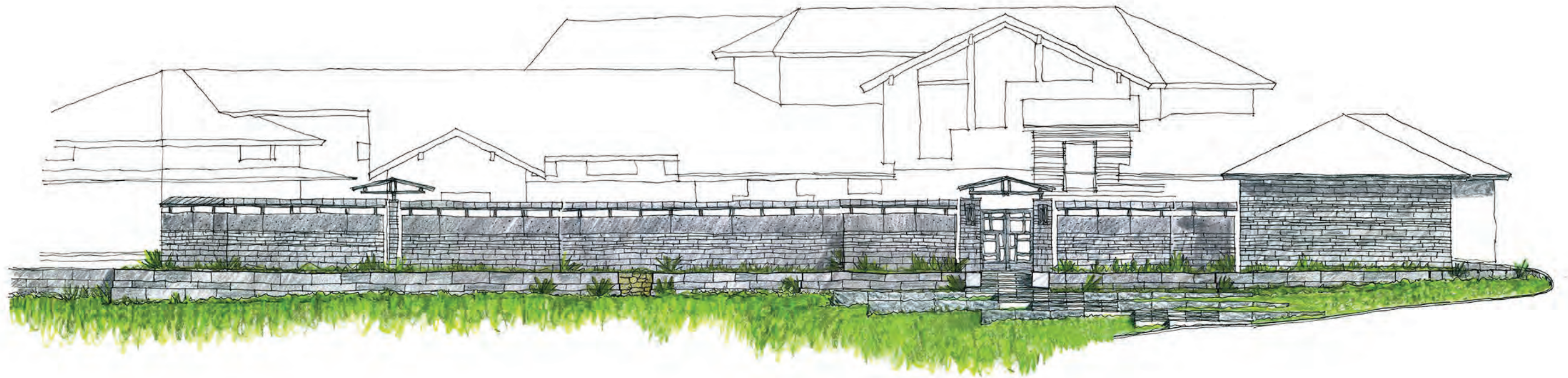

NIX GROUP  
ARCHITECTS



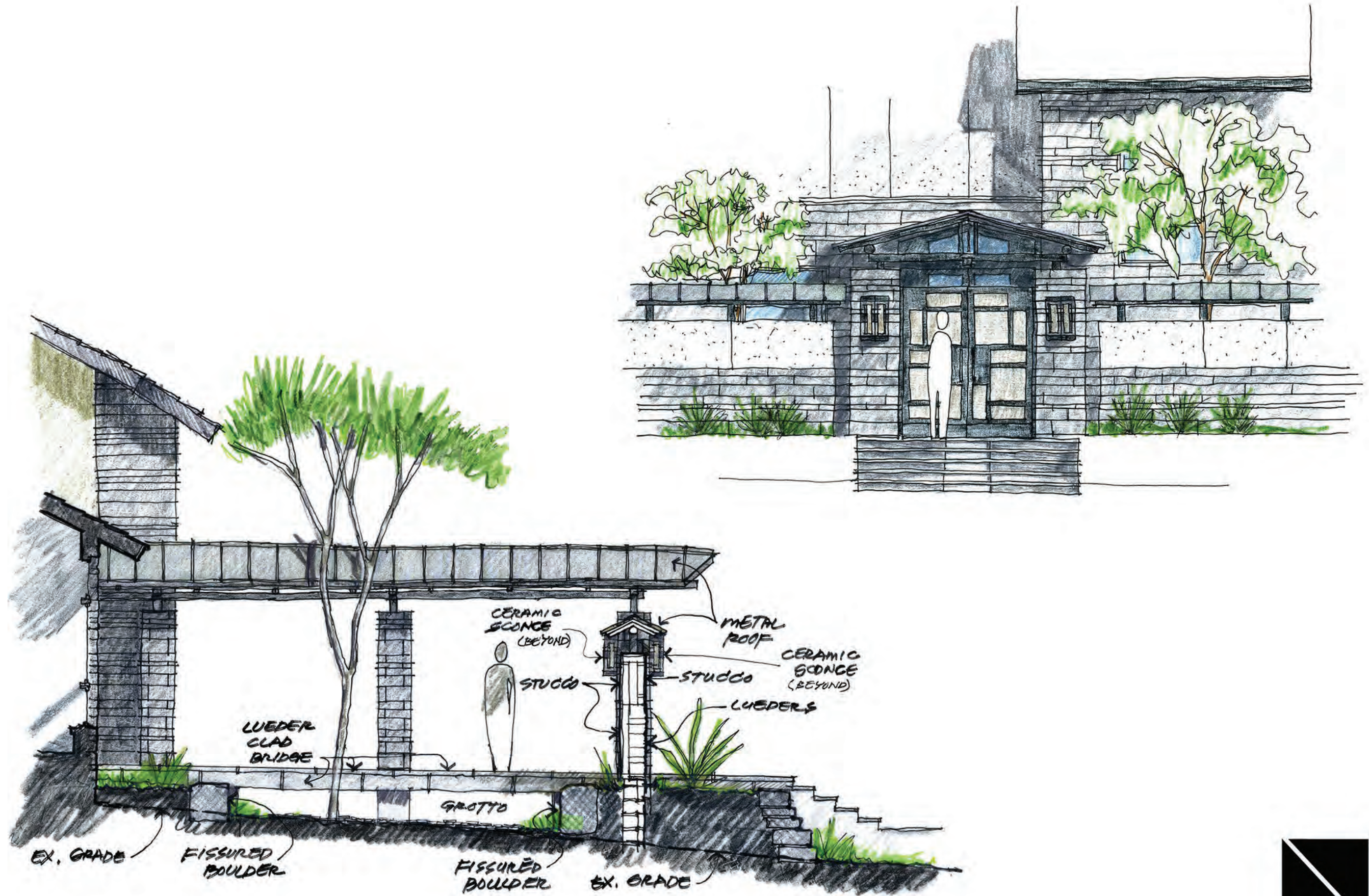







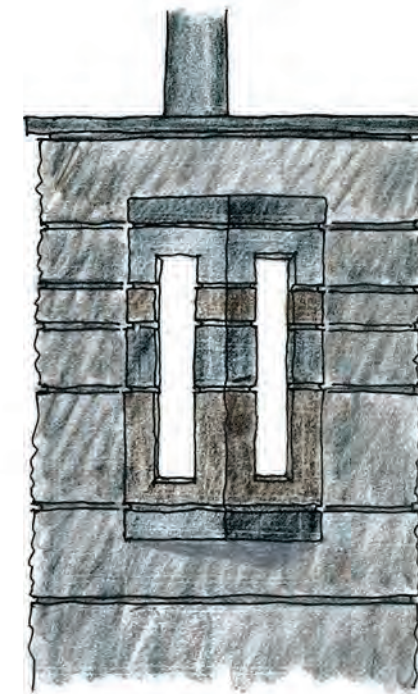
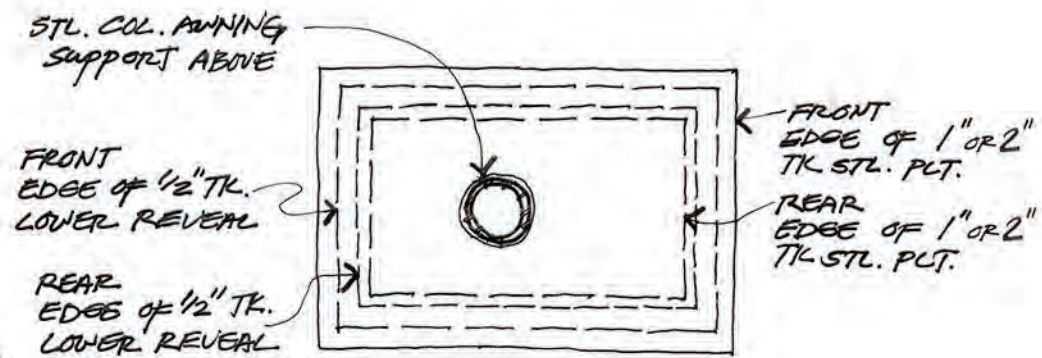
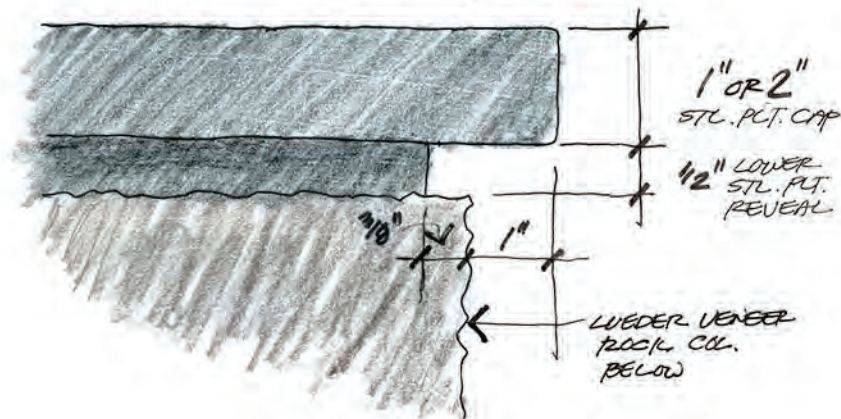
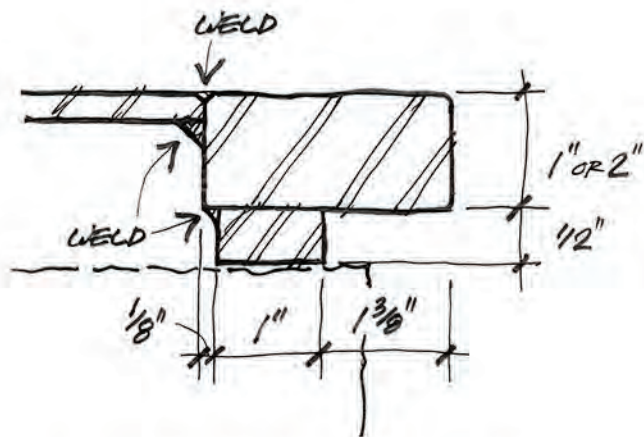
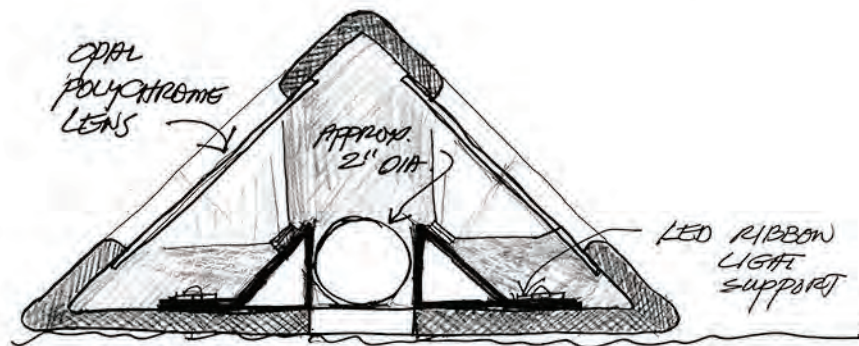
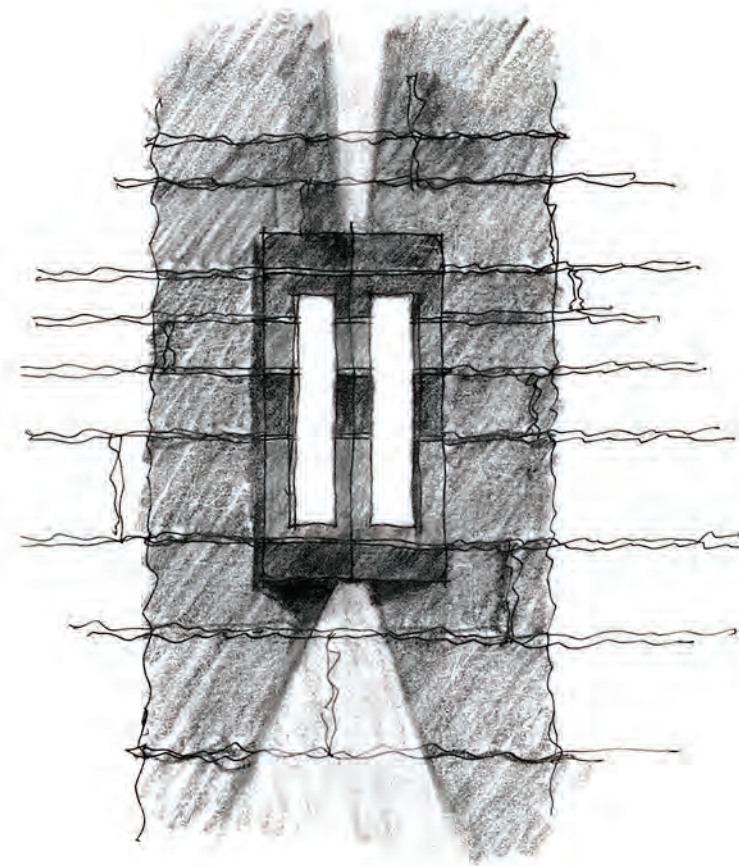
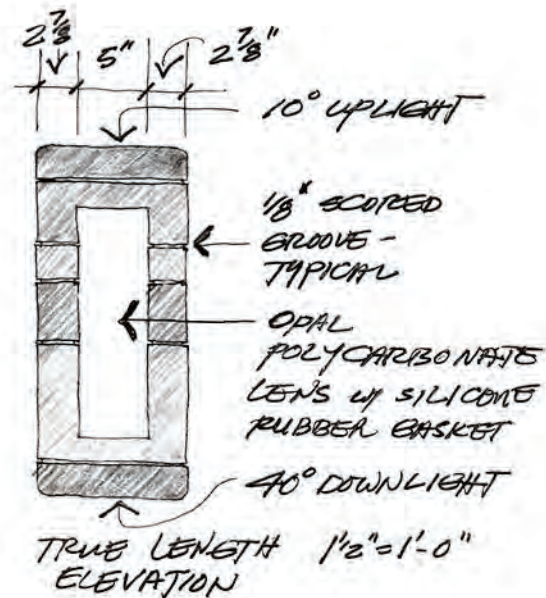
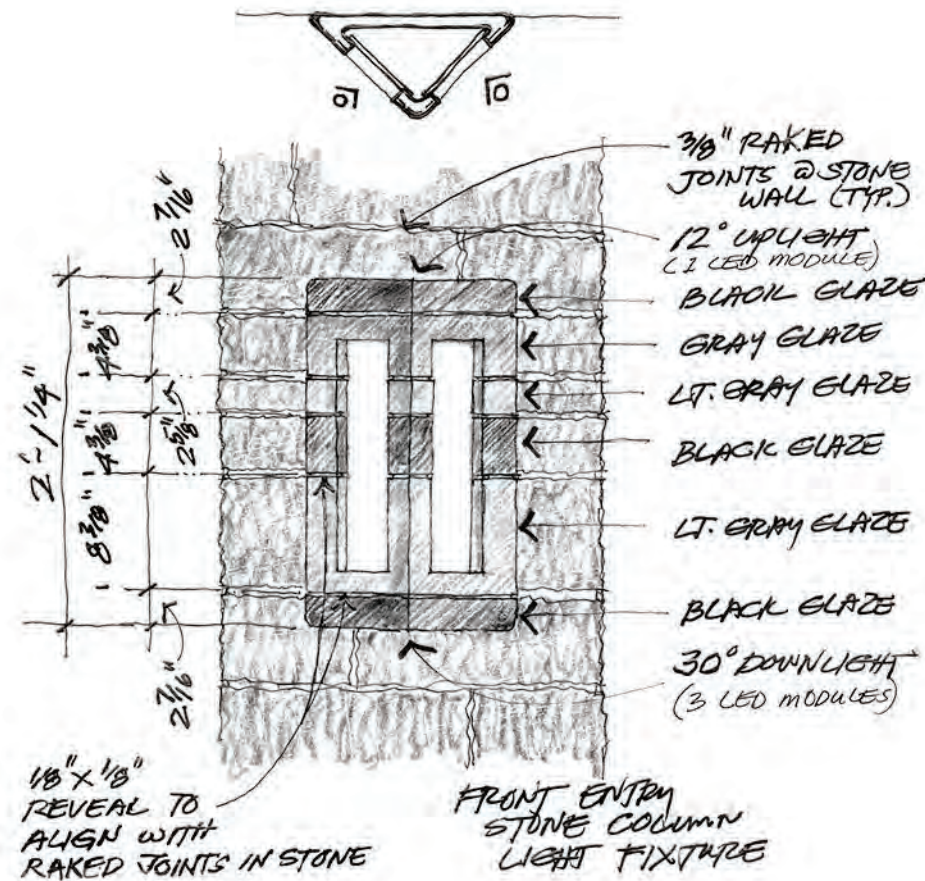

1" TK. @ SHORTER ROCK COLUMNS (10)  
 2" TK. @ TALLER ROCK COLUMNS (6)

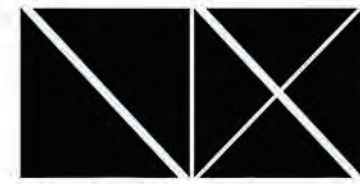

NIX GROUP ARCHITECTS



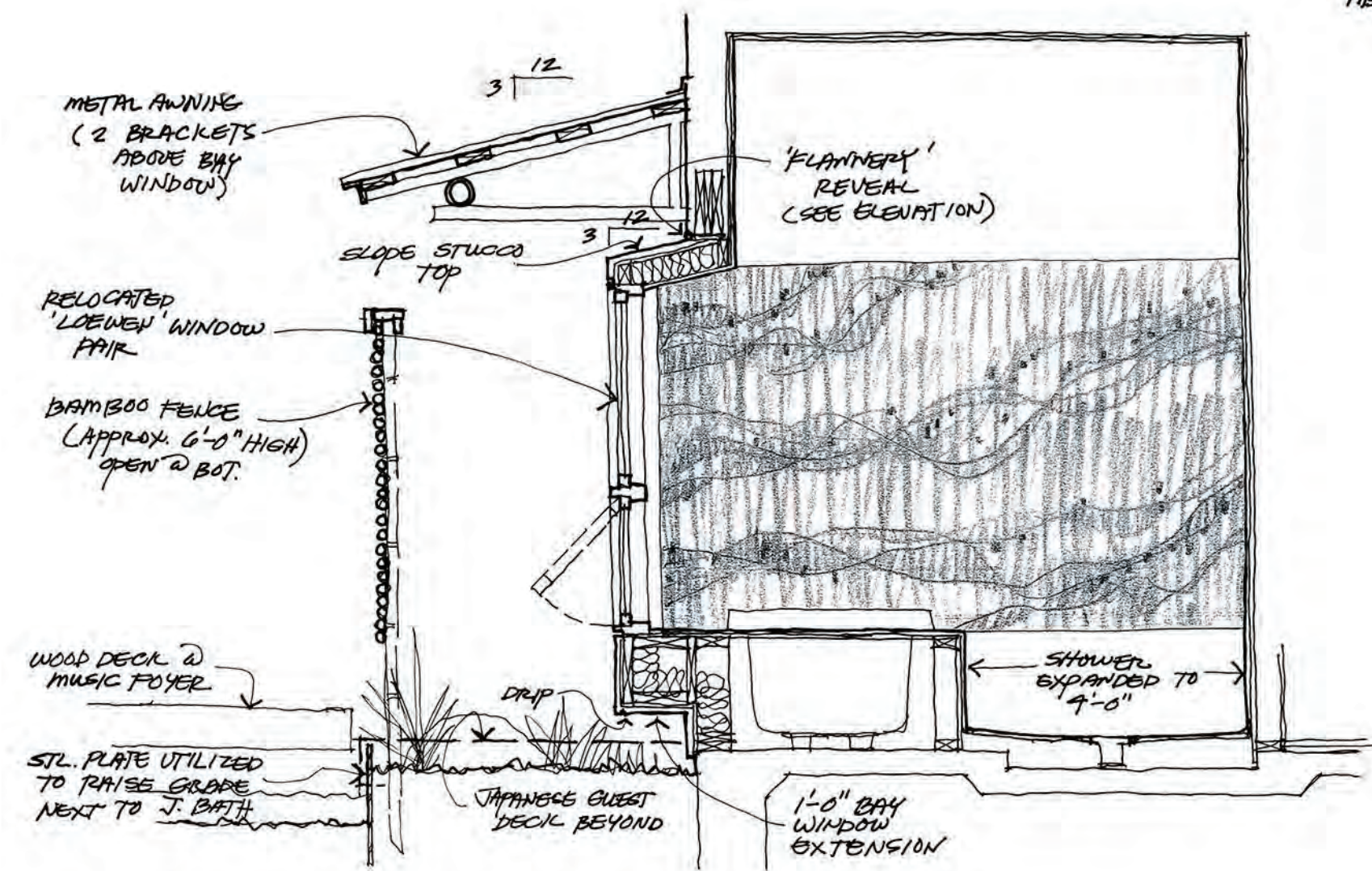
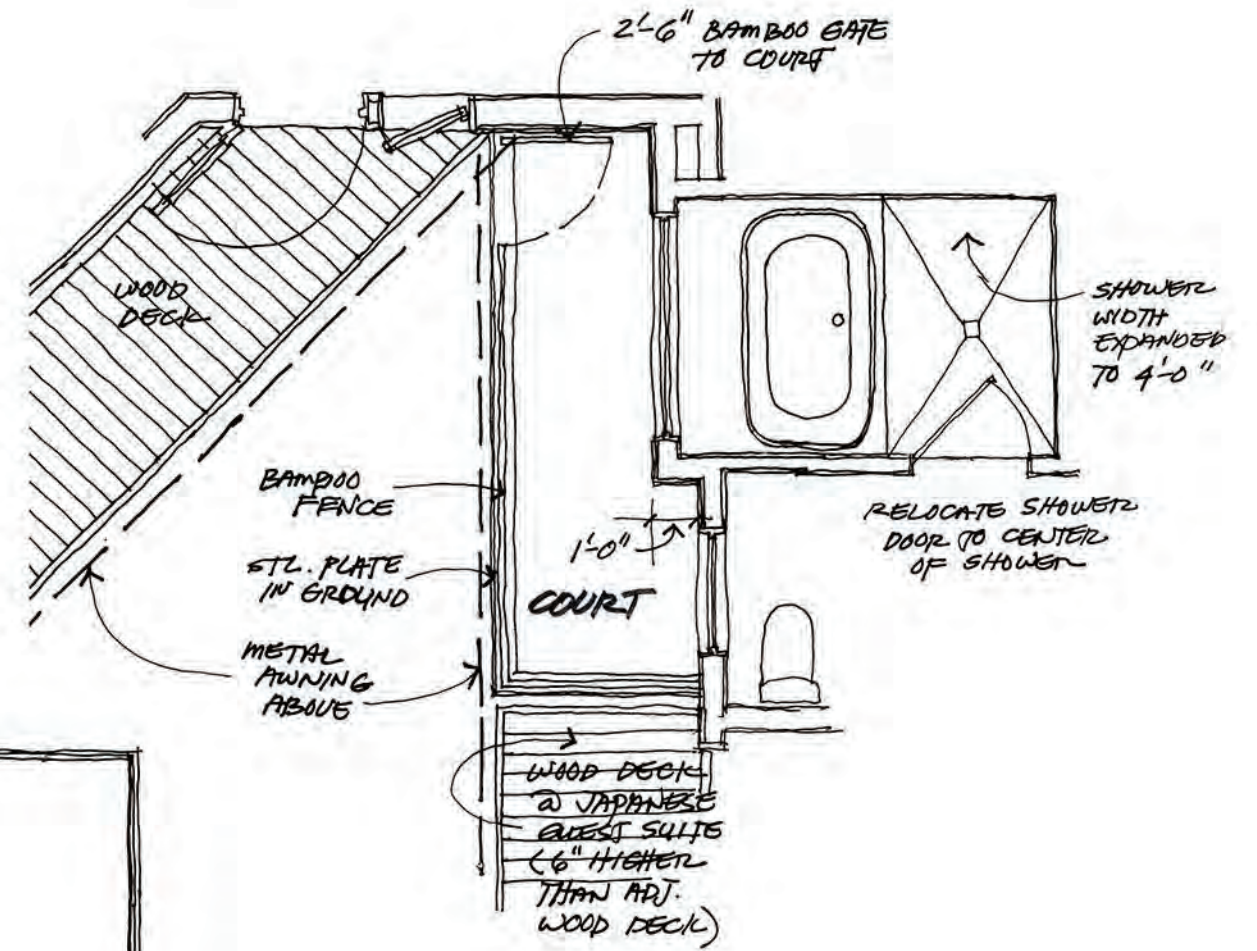



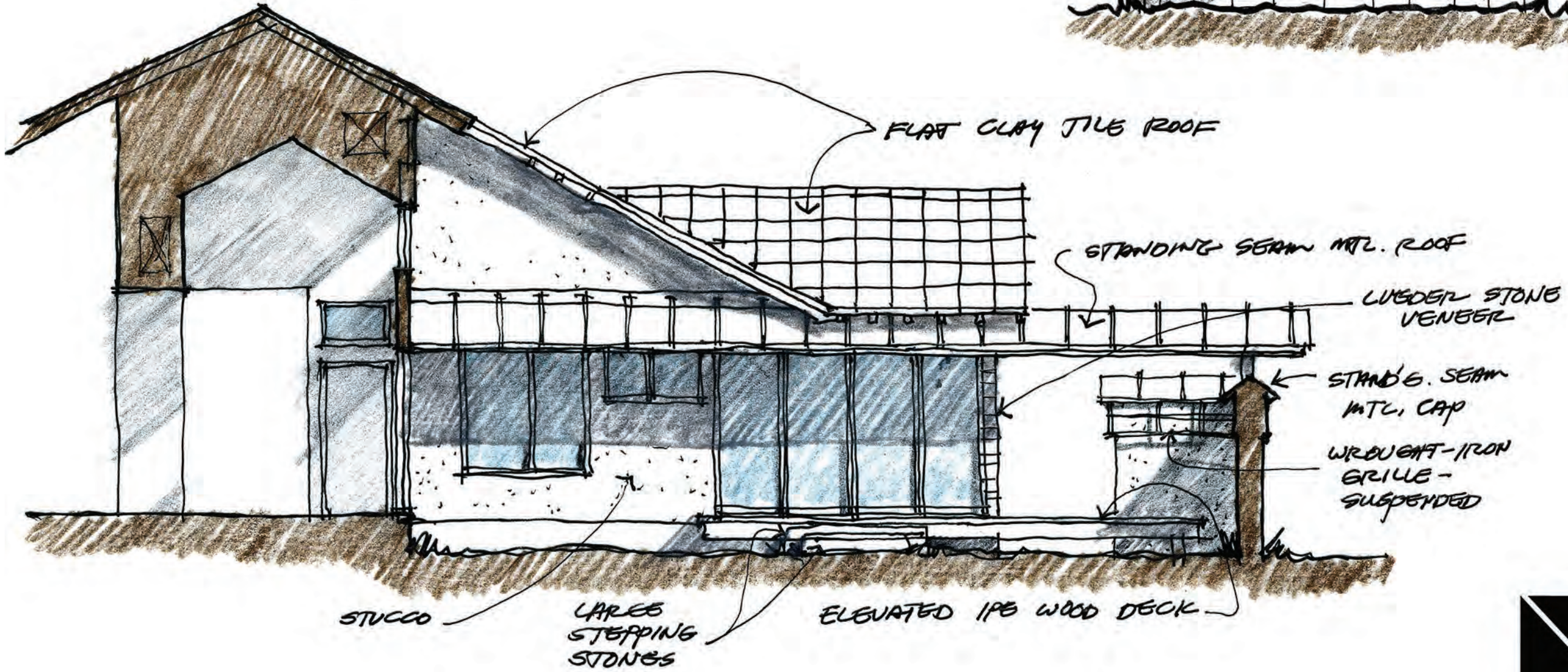
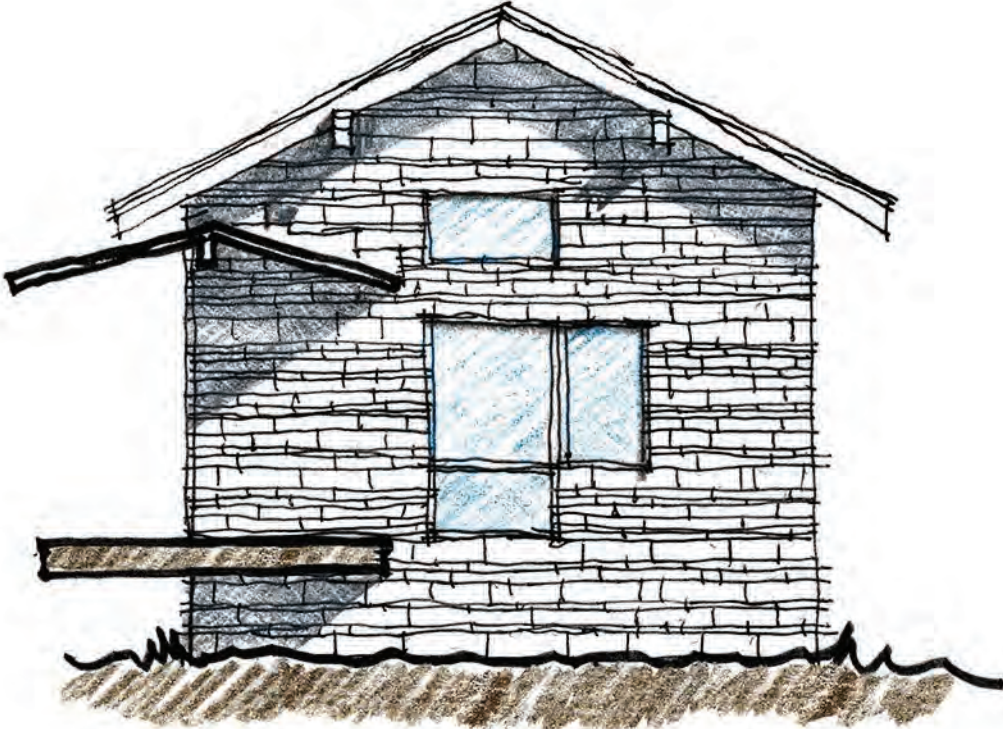



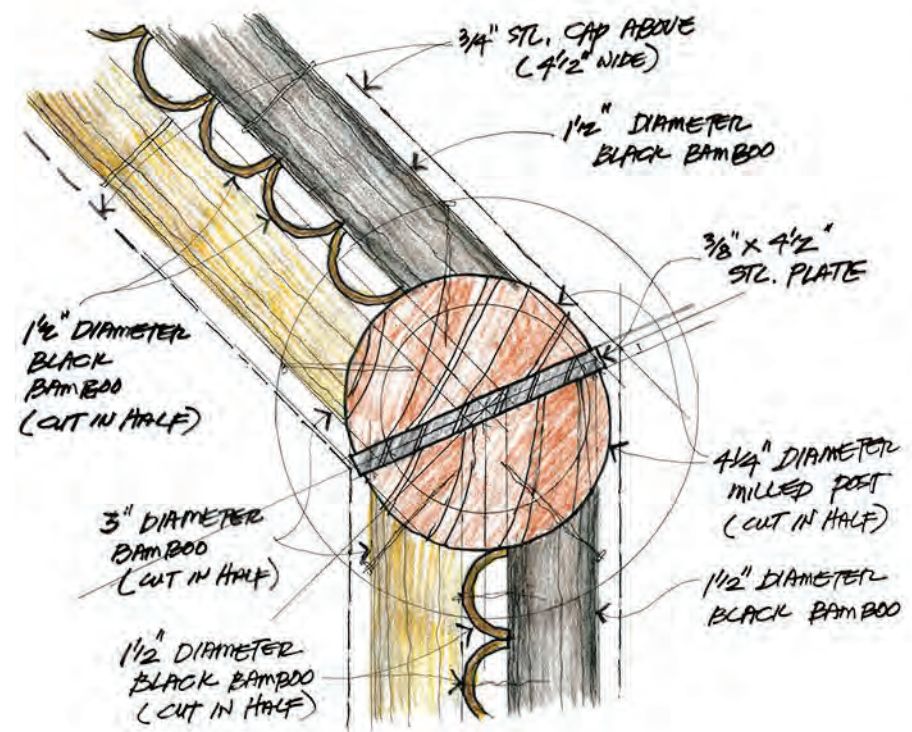
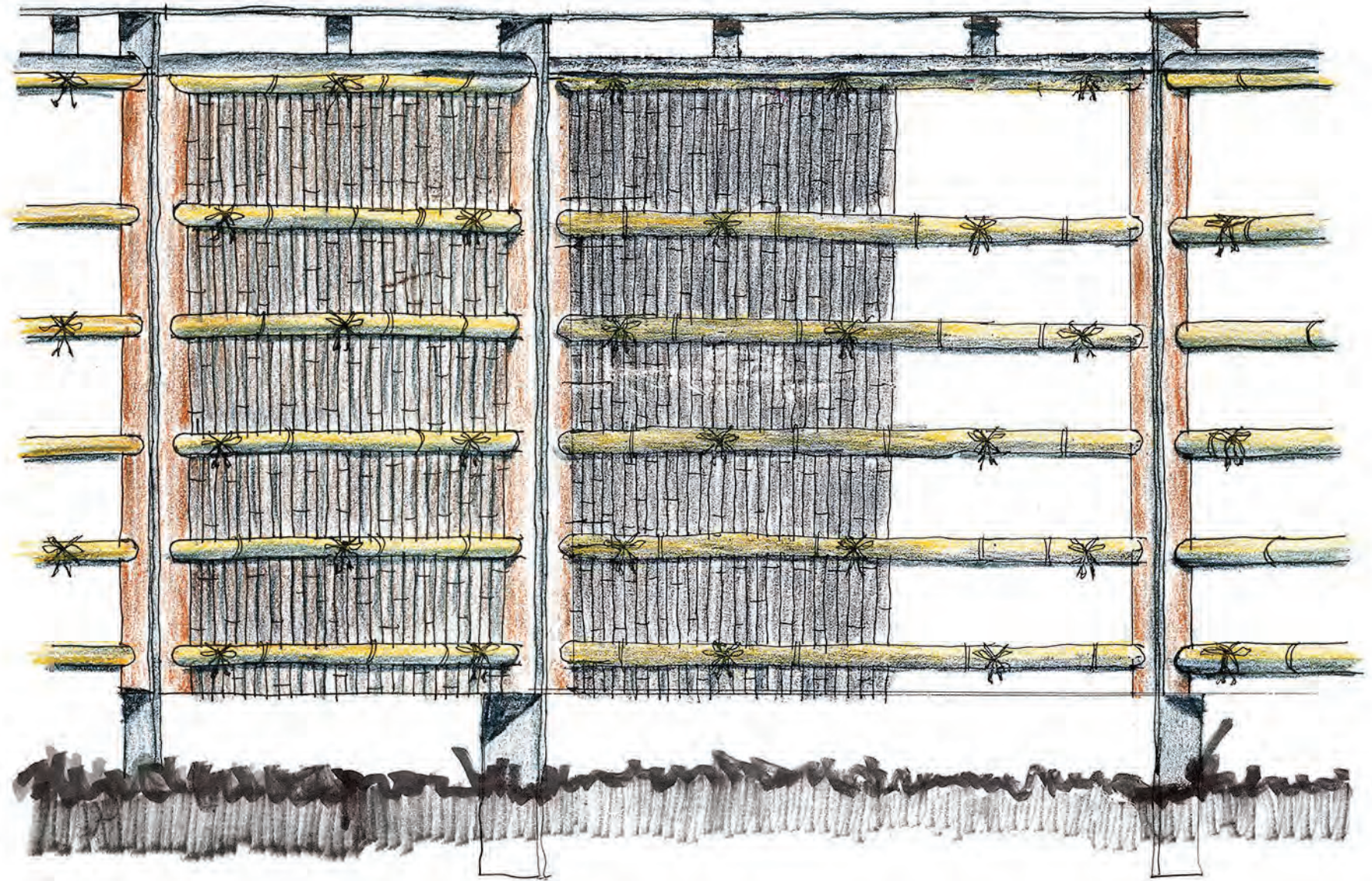
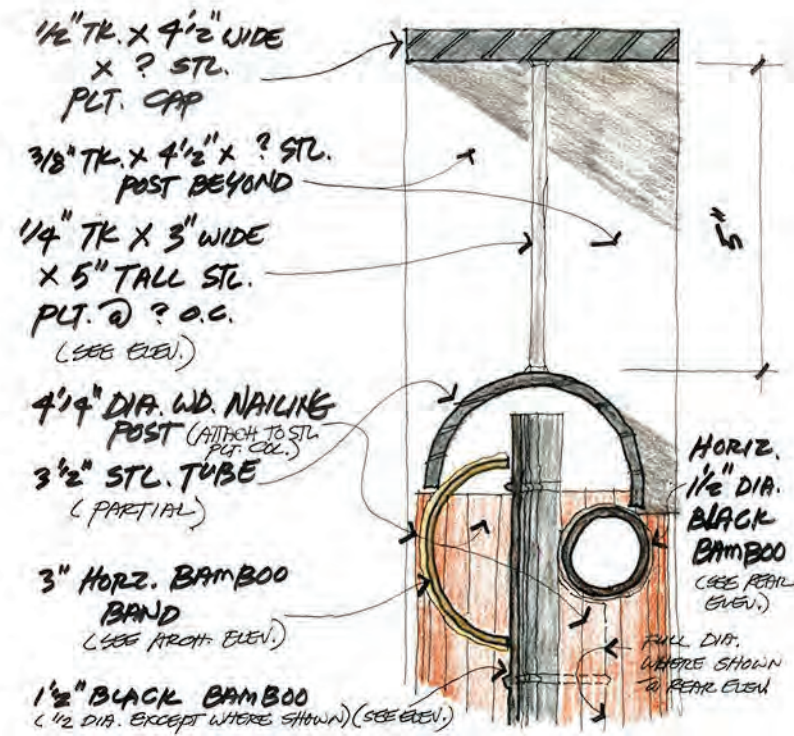

NIX GROUP  
ARCHITECTS







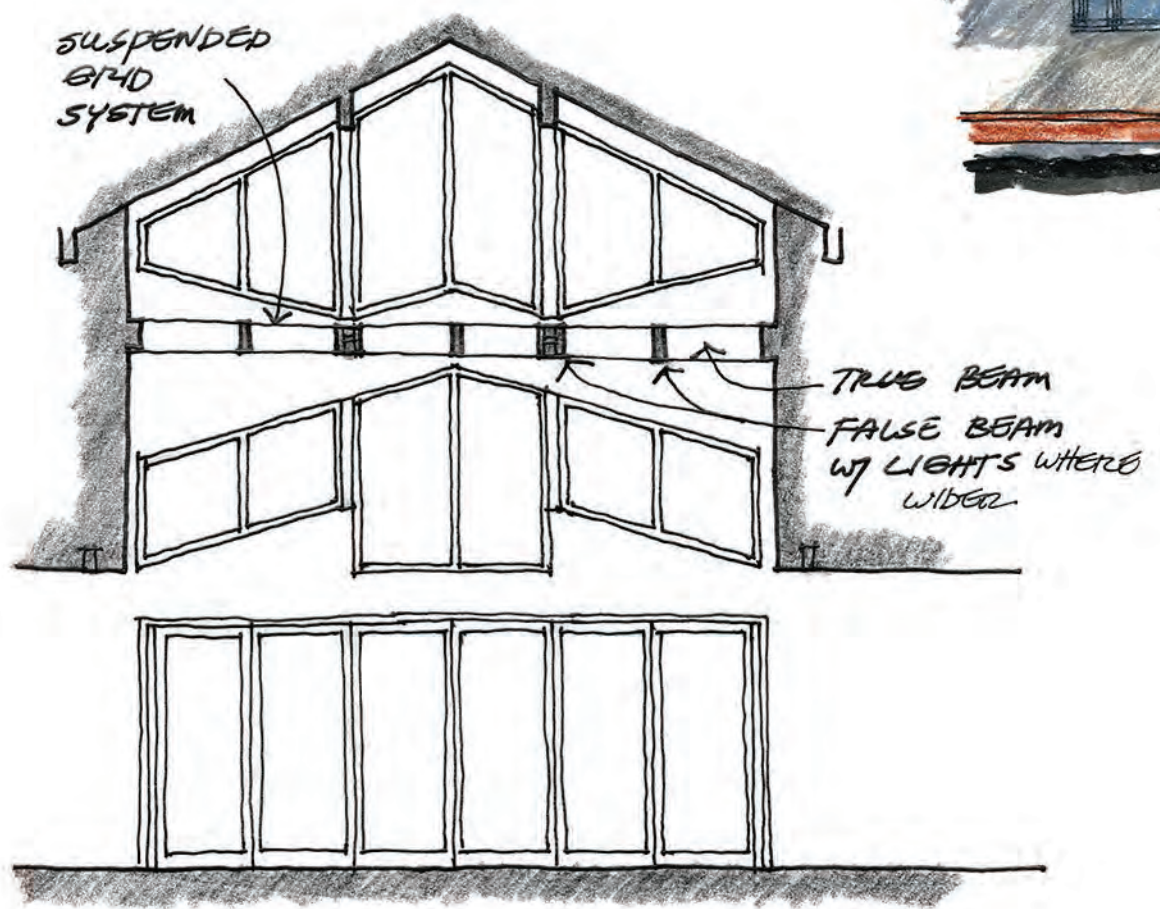



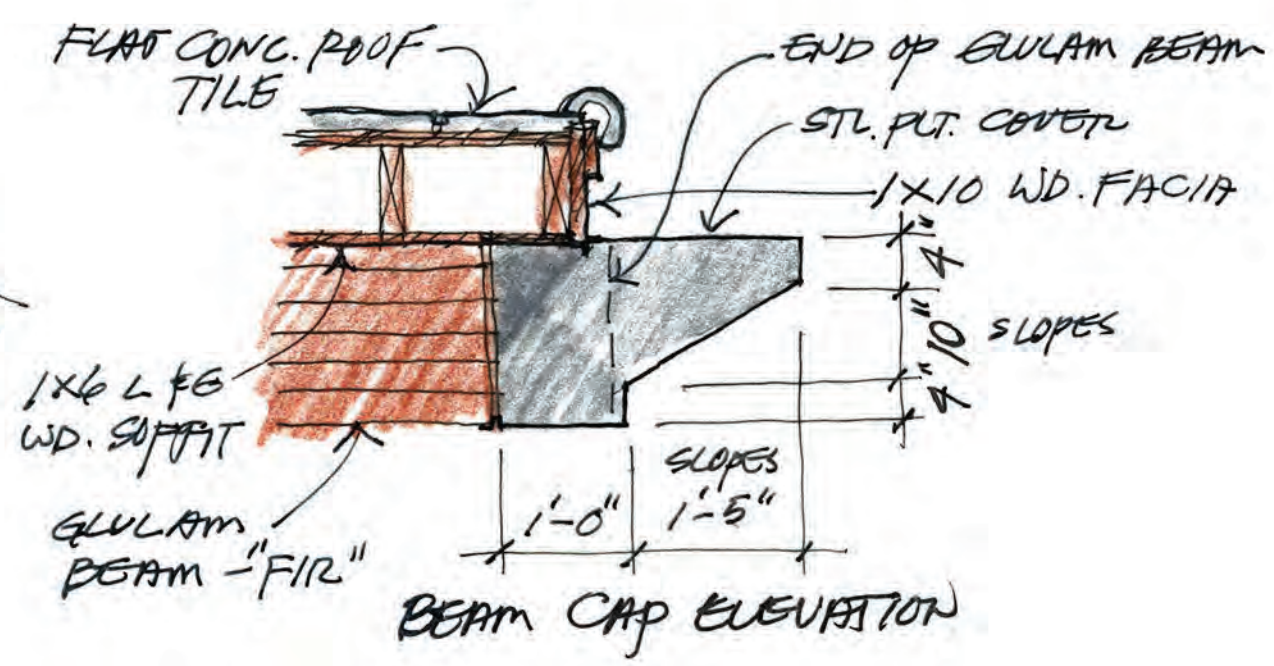
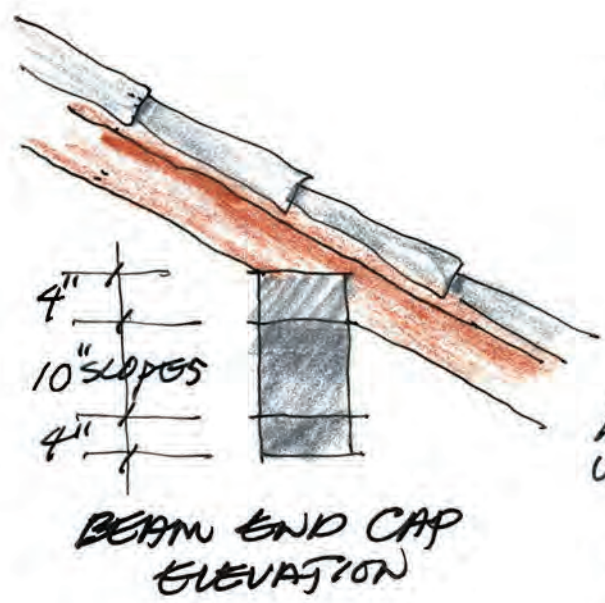
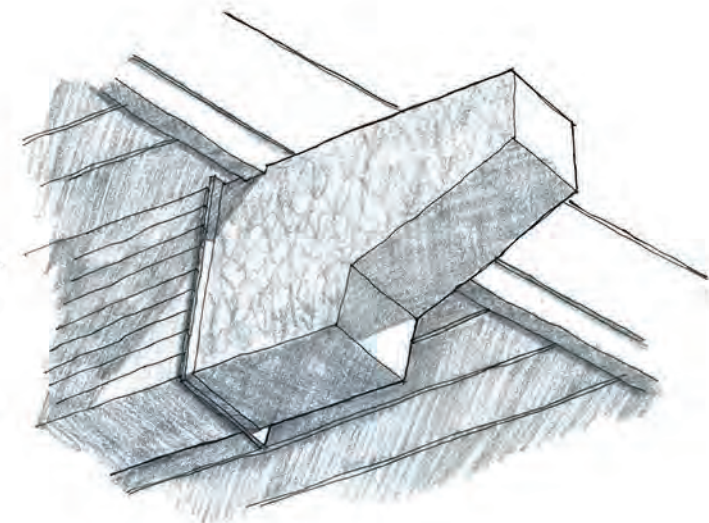
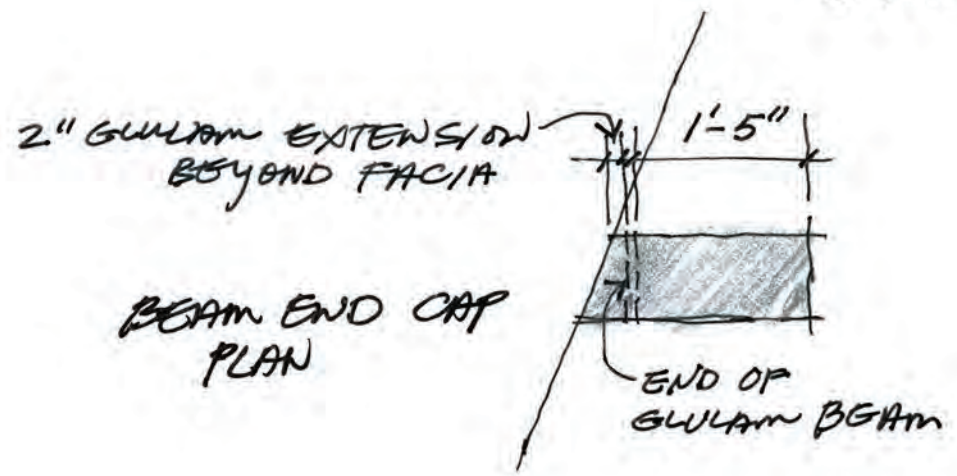
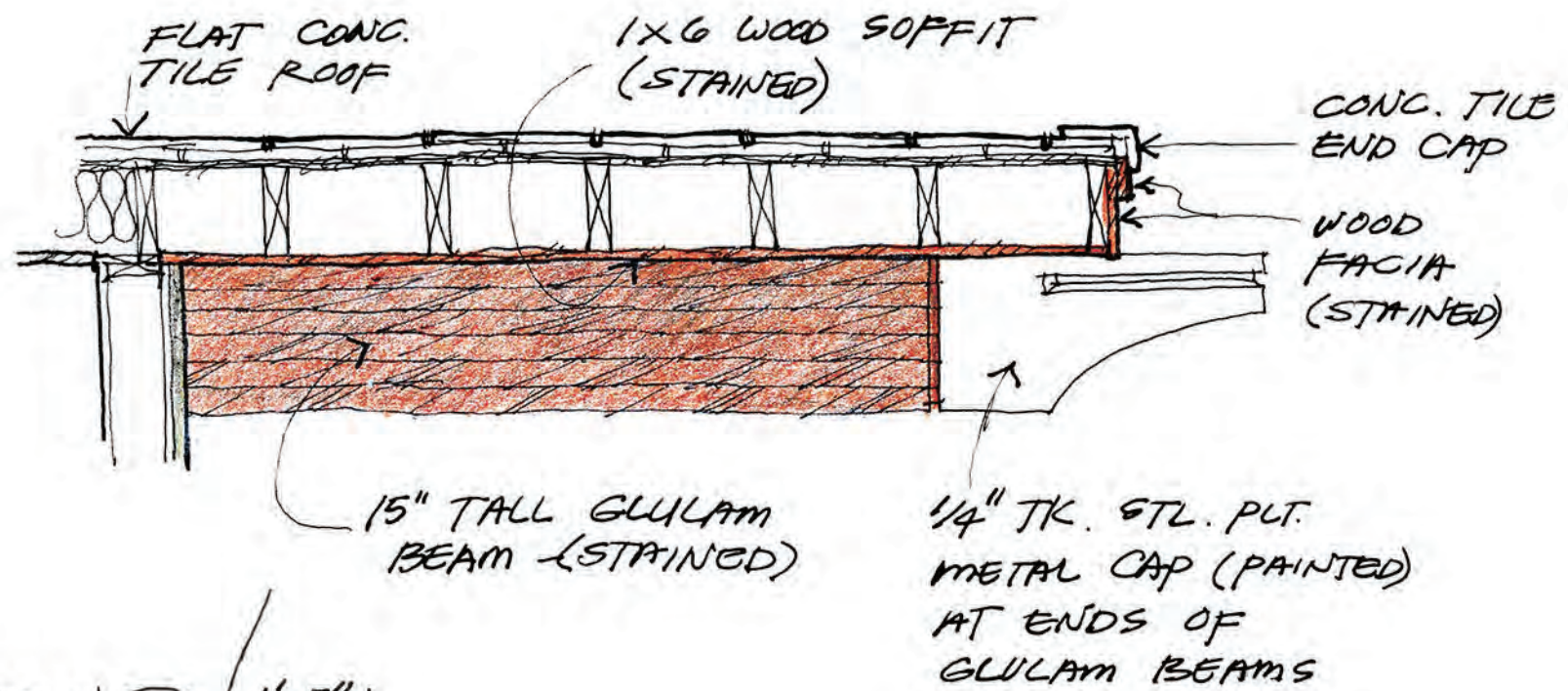
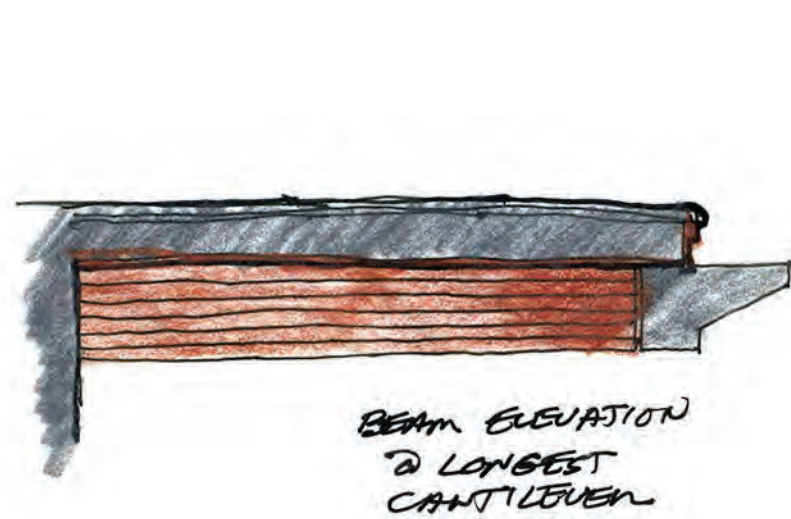



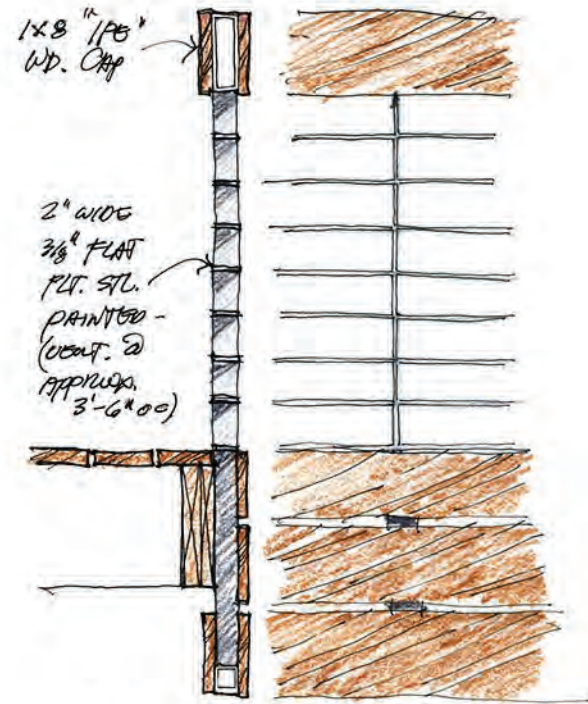

GUARDRAIL #1

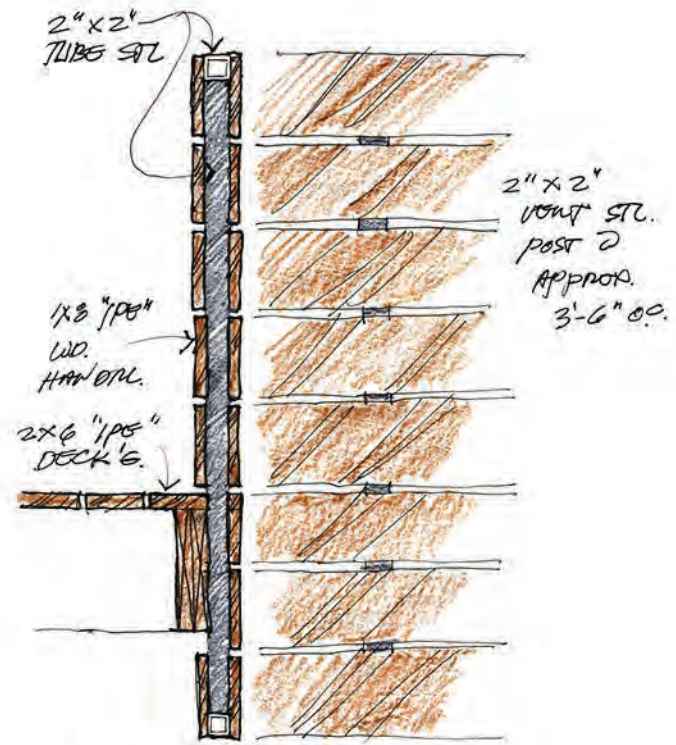
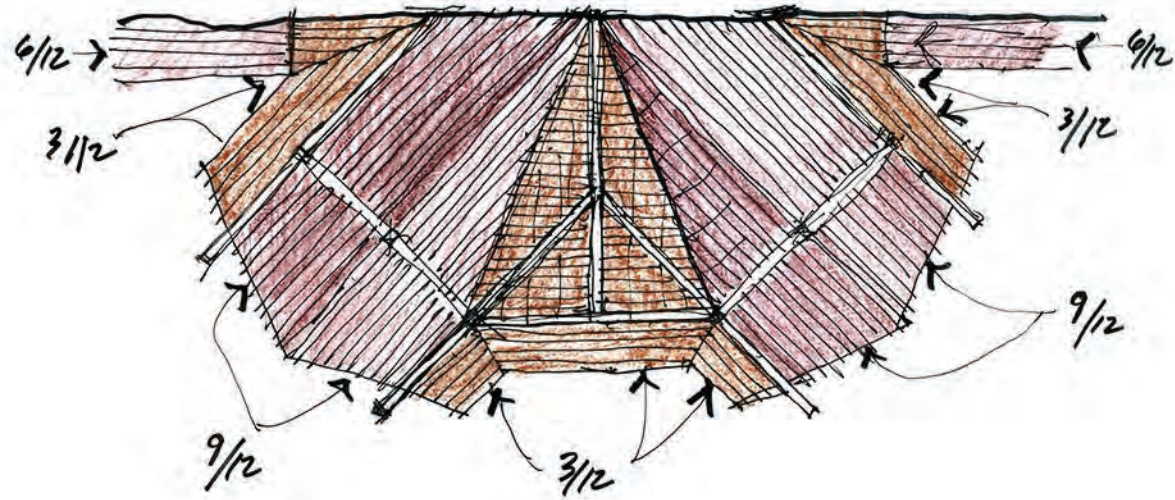

GUARDRAIL #2

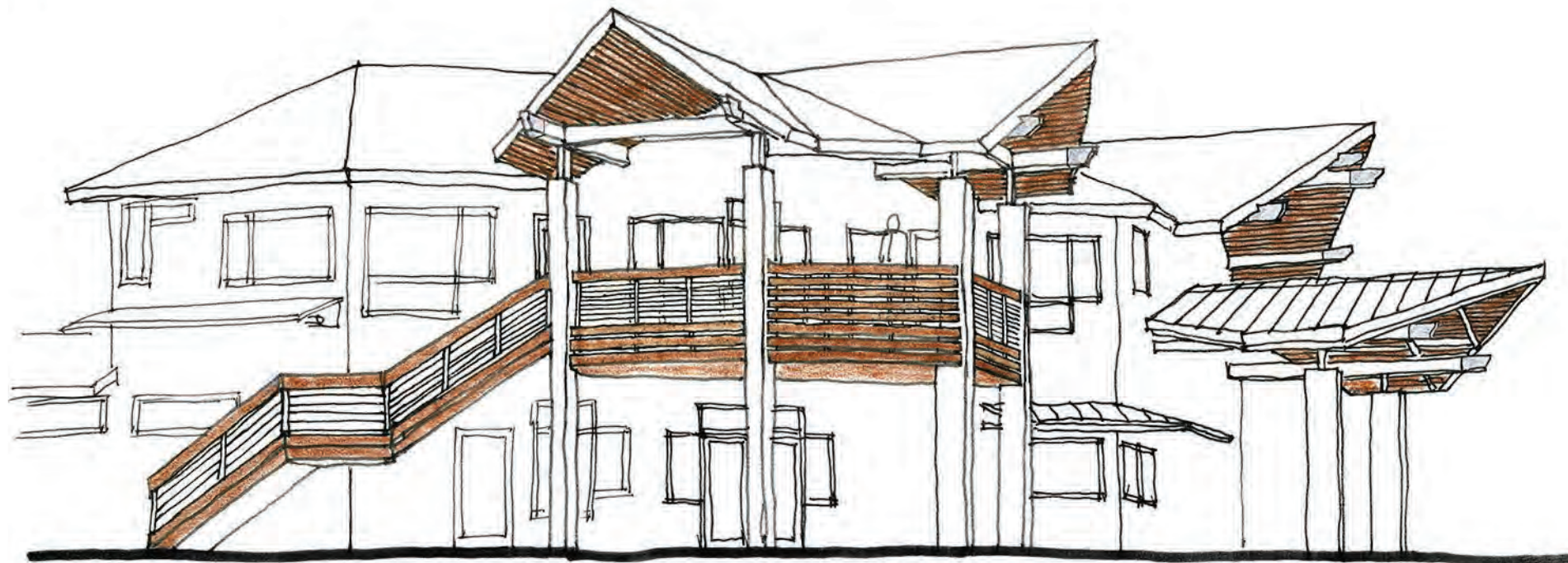

NIX GROUP  
ARCHITECTS



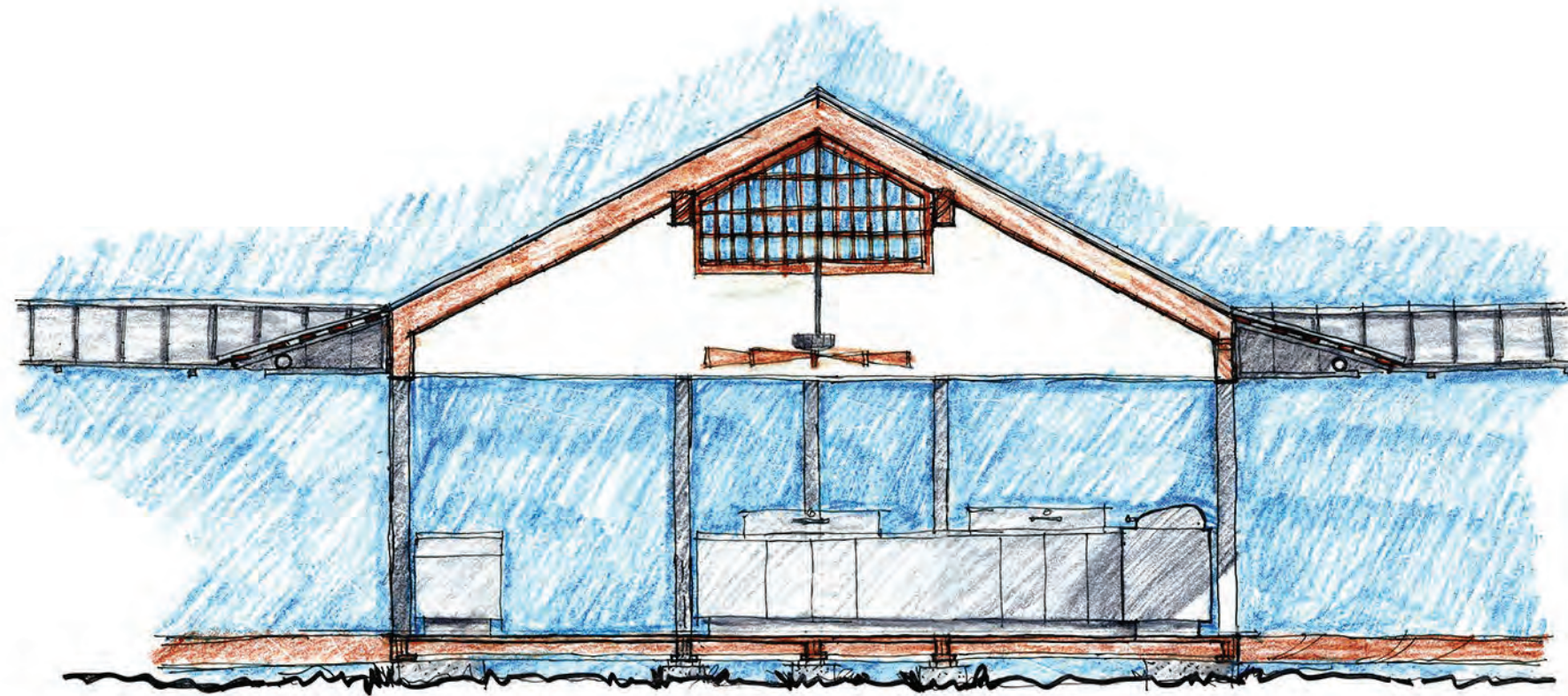

BUILDING SECT # B-B  
@ CABANA

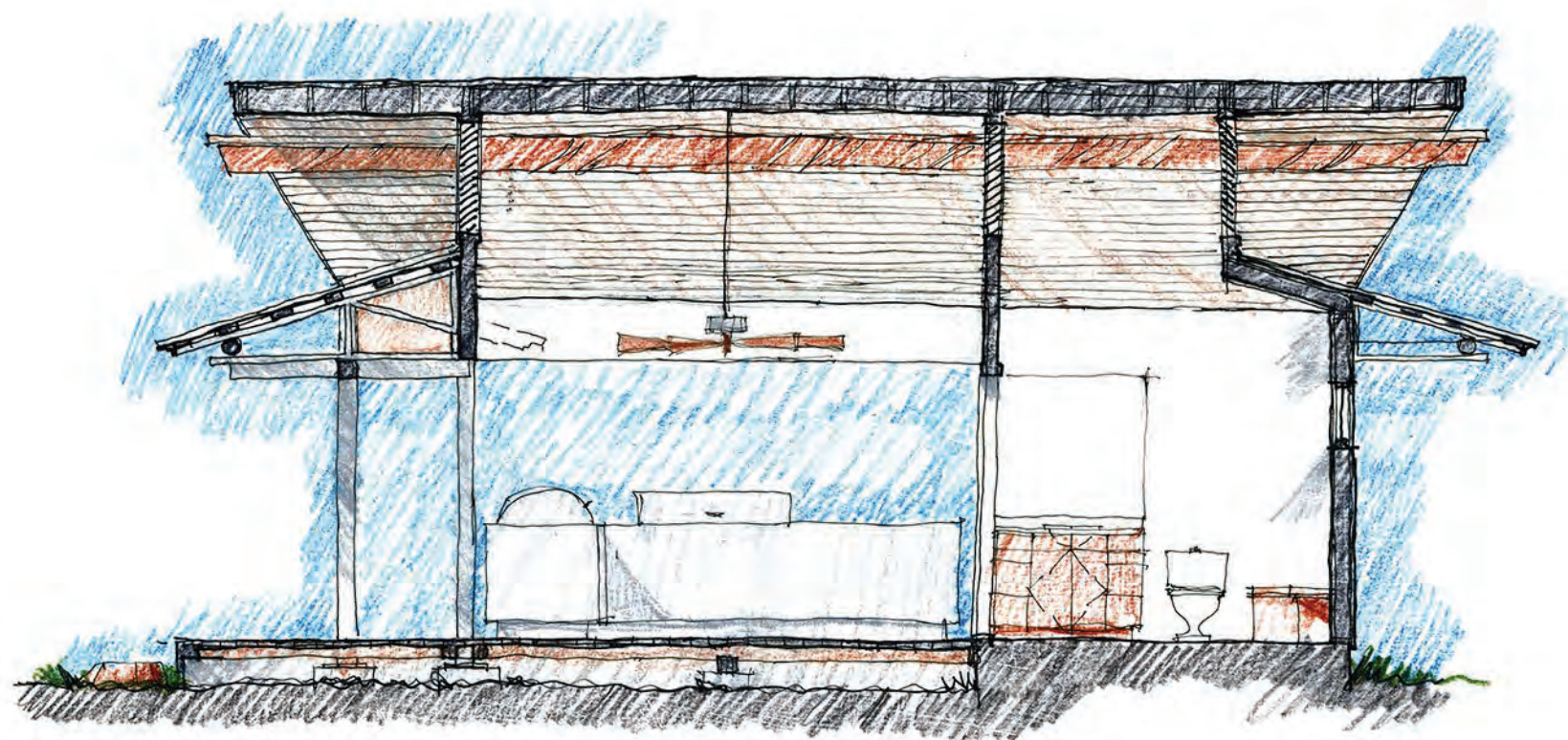

BUILDING SECT # A-A  
@ CABANA



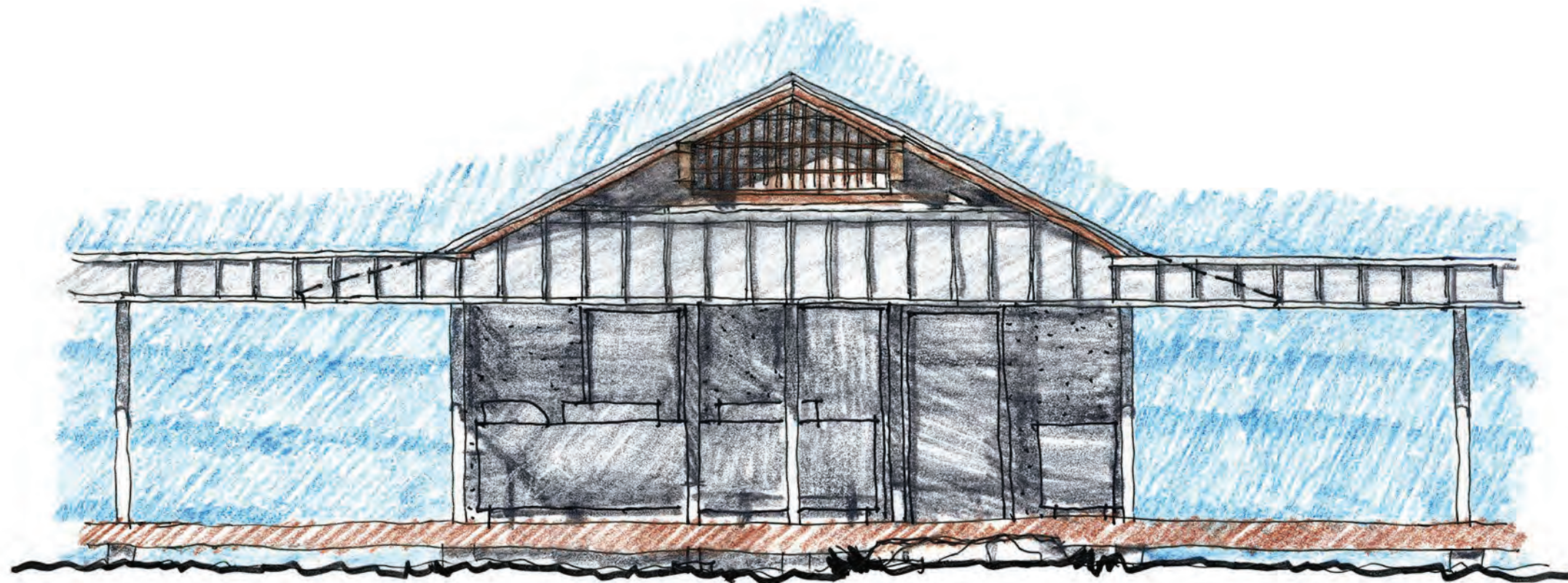

ELEVATION

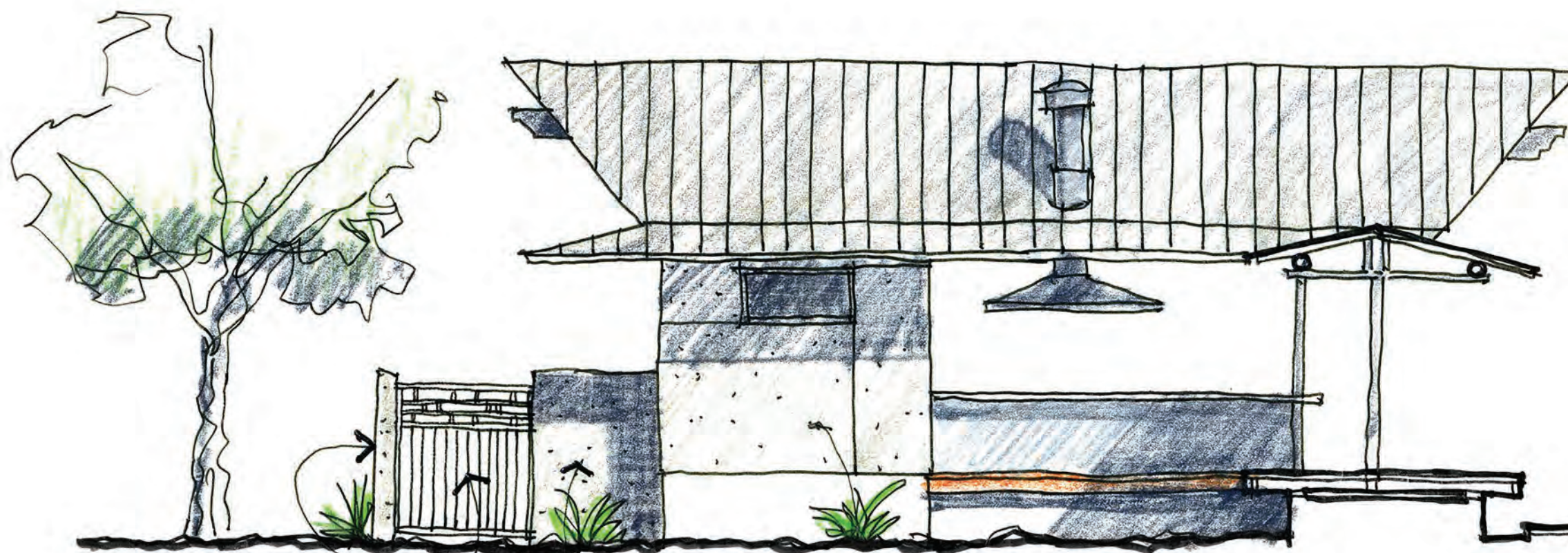

WROUGHT IRON FENCE  
(MATCHES ENTRY COURT AND  
UTILITY COURT FENCES)

POOL EQUIPMENT  
SCREEN WALL



NIX GROUP  
ARCHITECTS



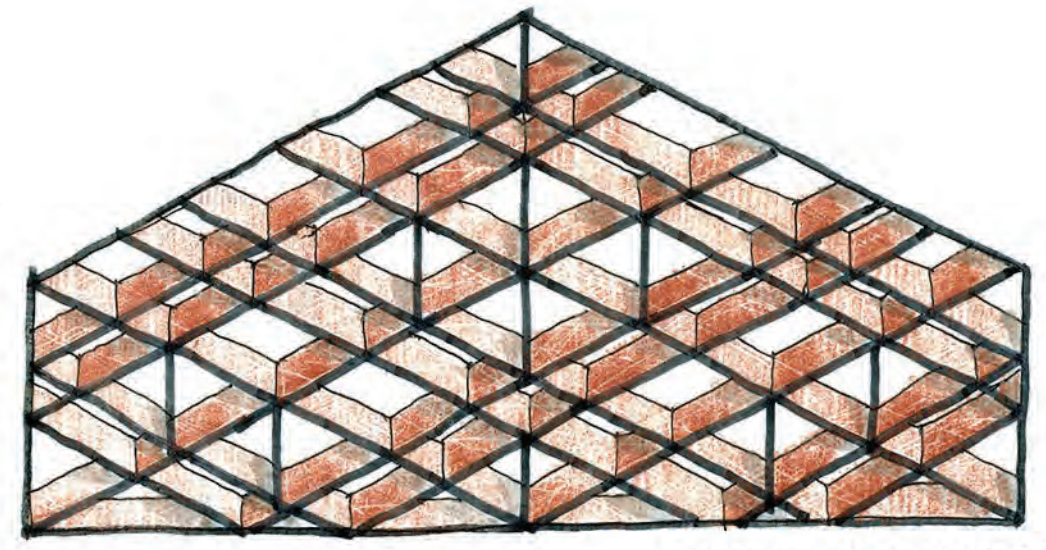
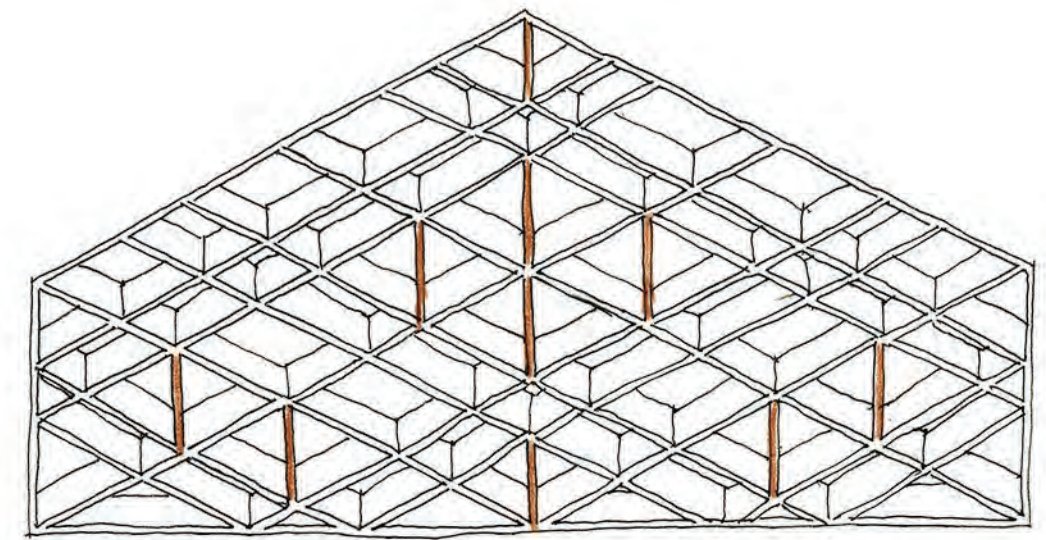
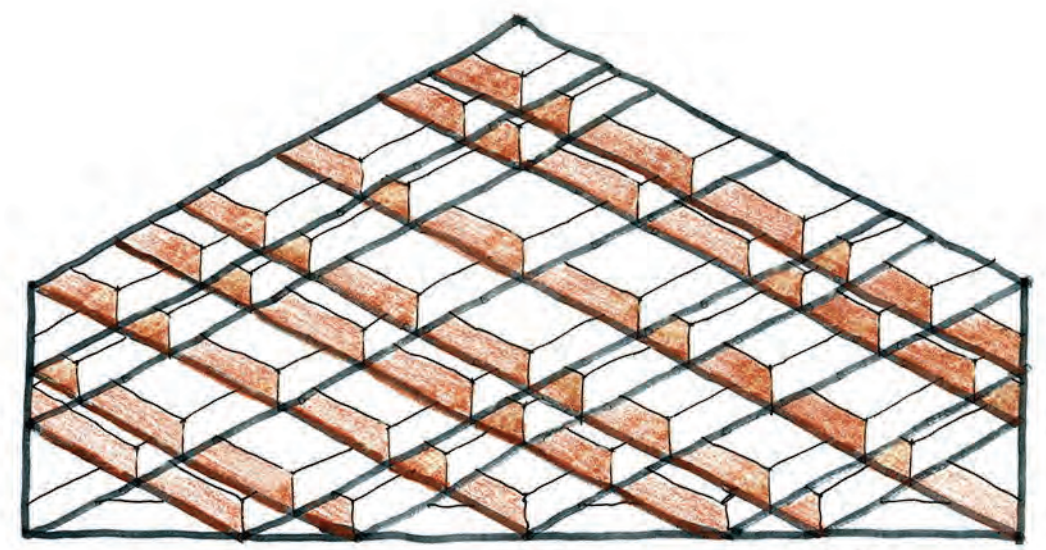
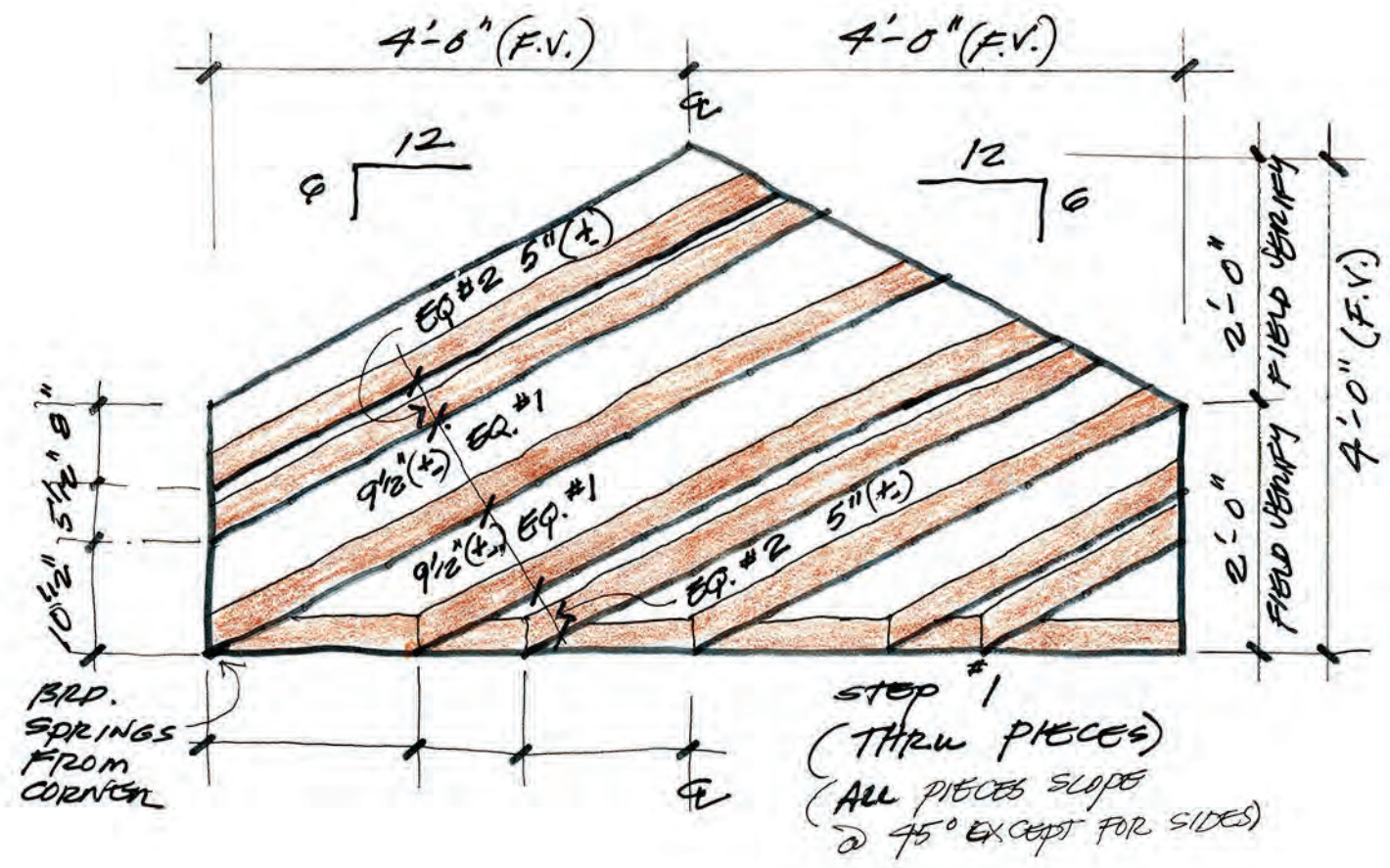



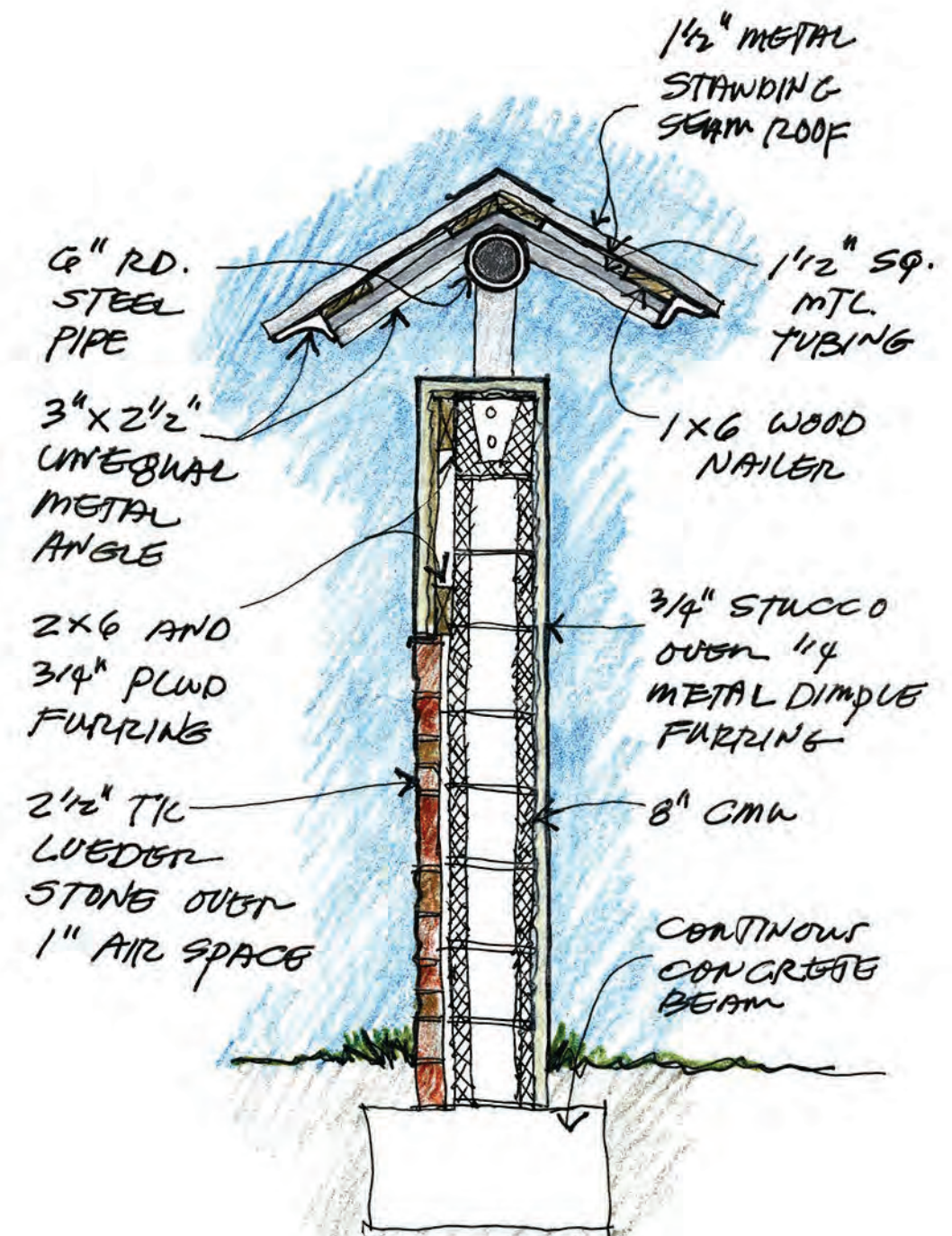
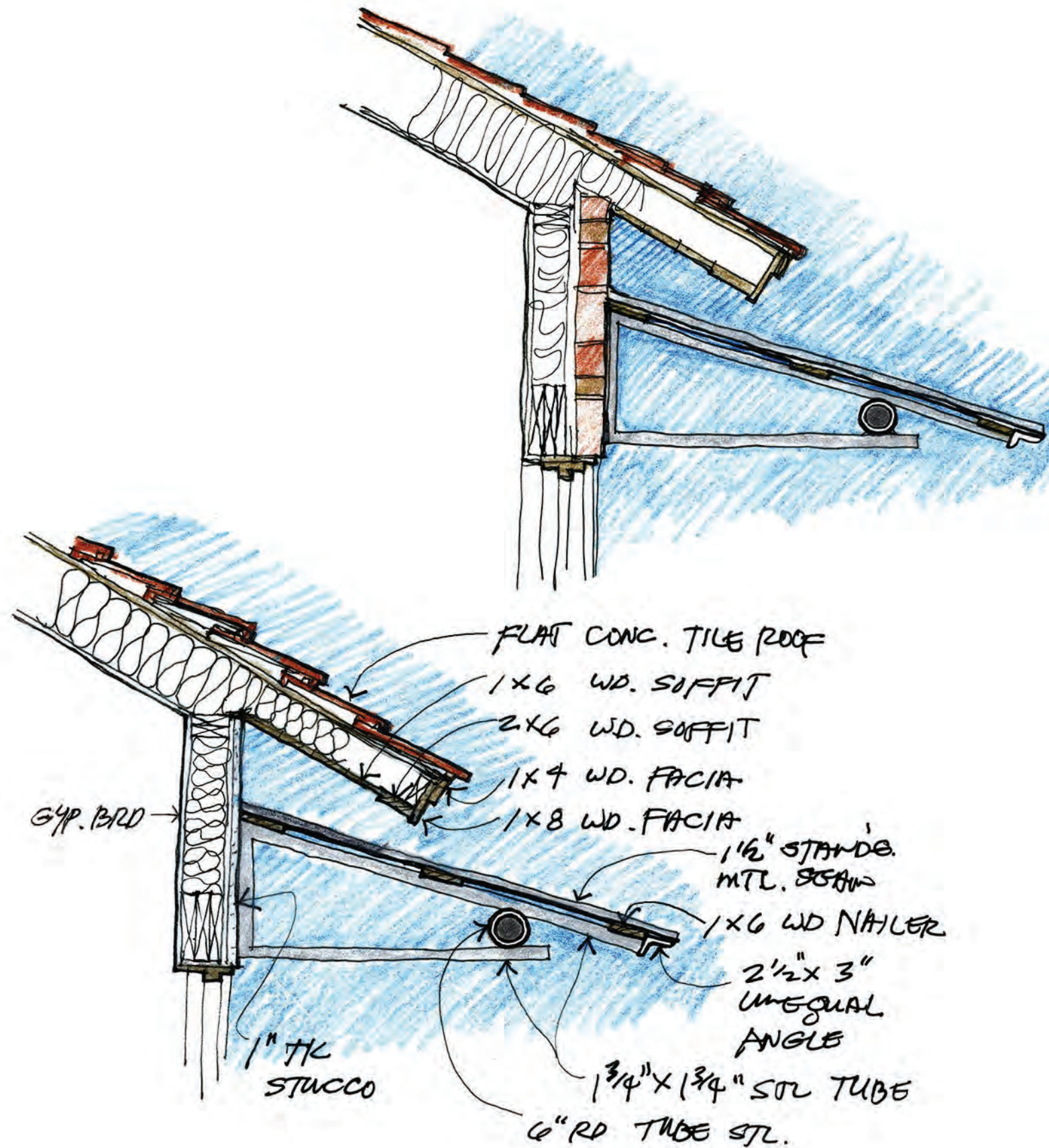



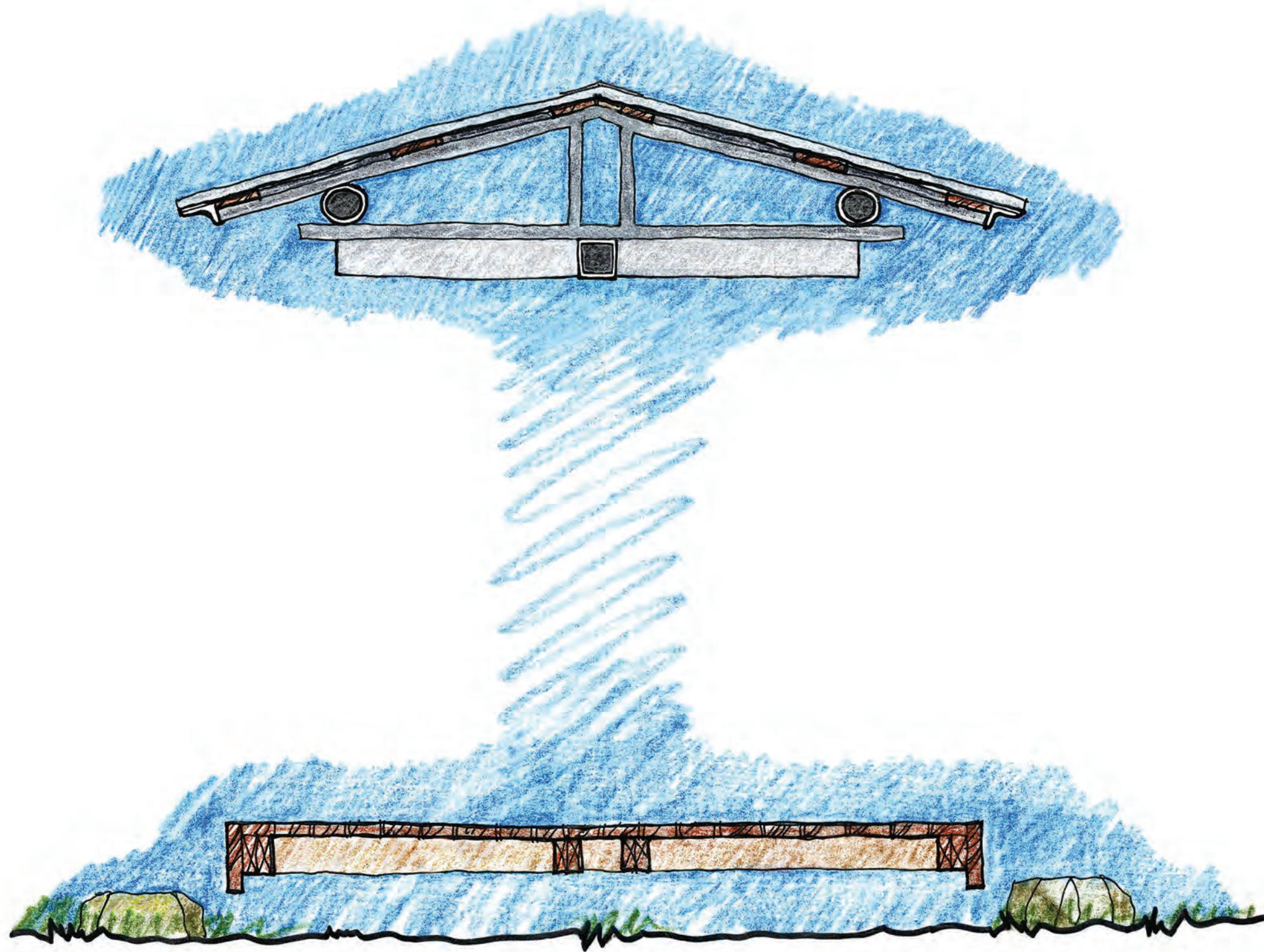

FRAME "D"  
WALKWAY TO AND PAST CABANA



NIX GROUP  
ARCHITECTS





NIX GROUP  
ARCHITECTS



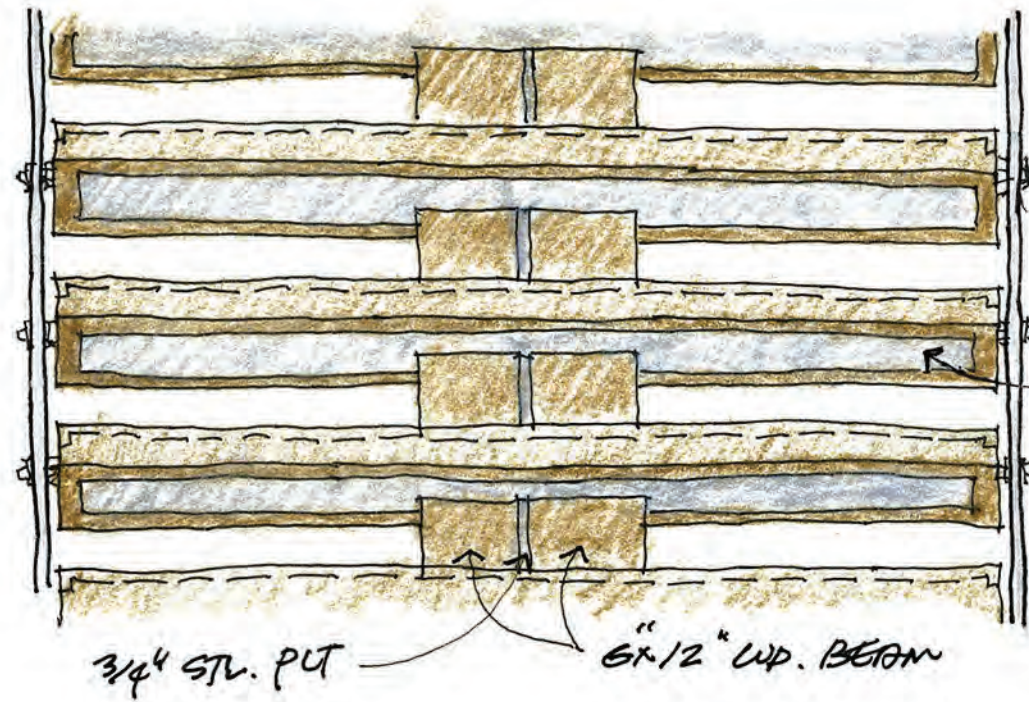

STAND-OFF  
GLASS SUPPORT  
BOLT

1/2" RECESSED  
STL. THREAD  
SUPPORT PLATE

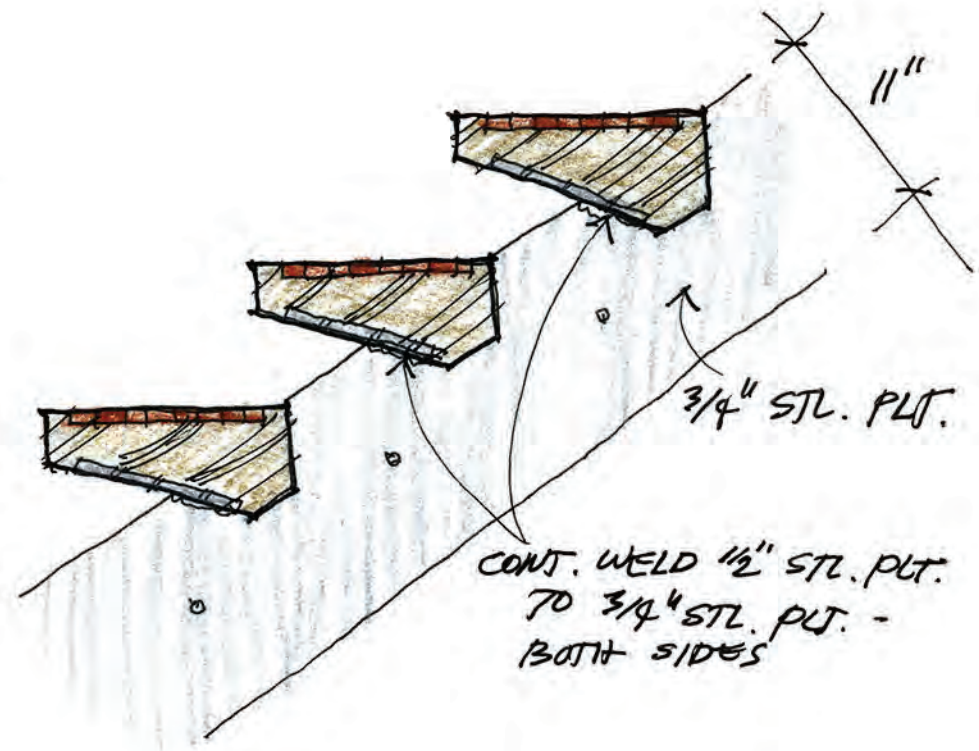

11"

3/4" STL. PLT.

CONT. WELD 1/2" STL. PLT.  
TO 3/4" STL. PLT. -  
BOTH SIDES

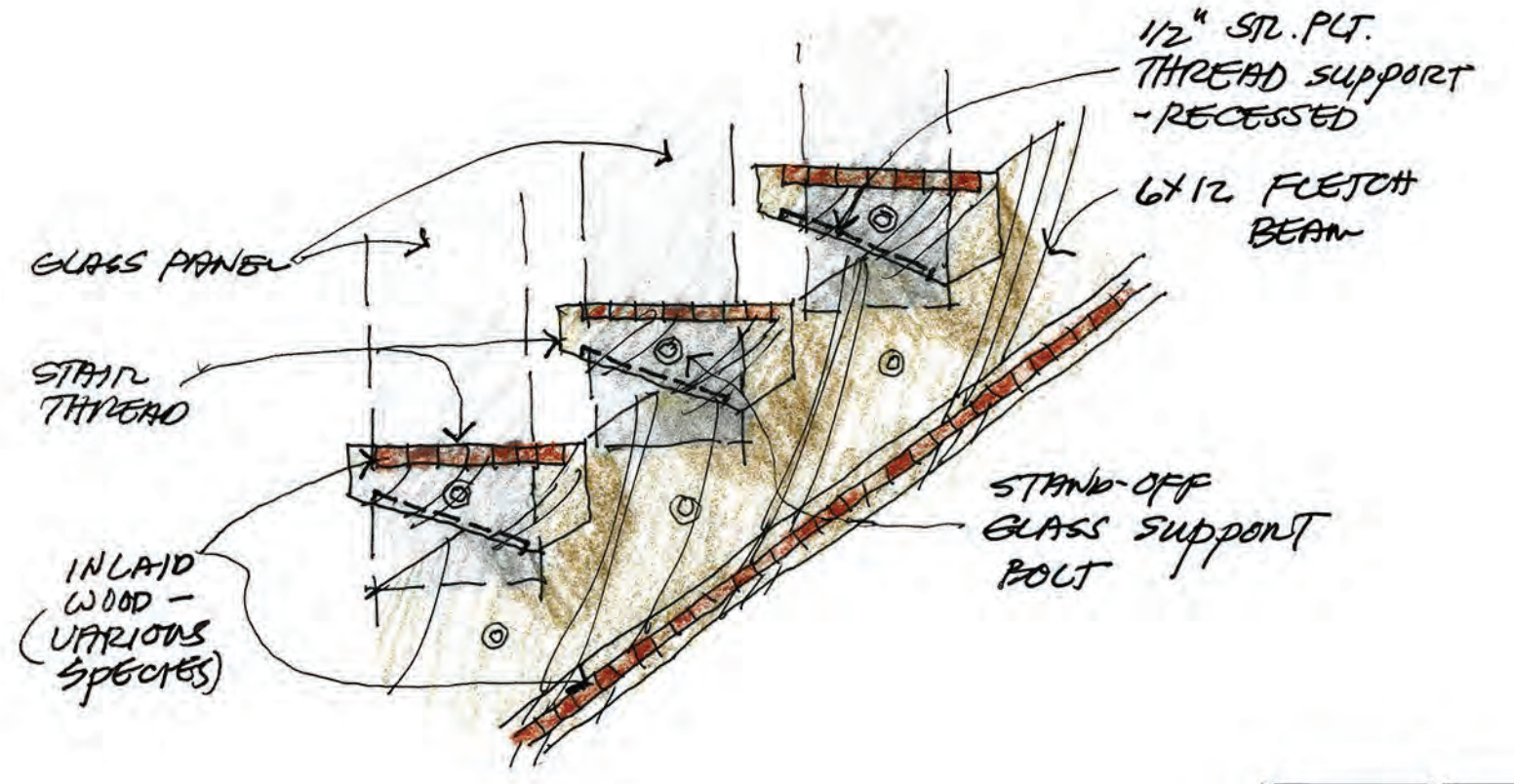
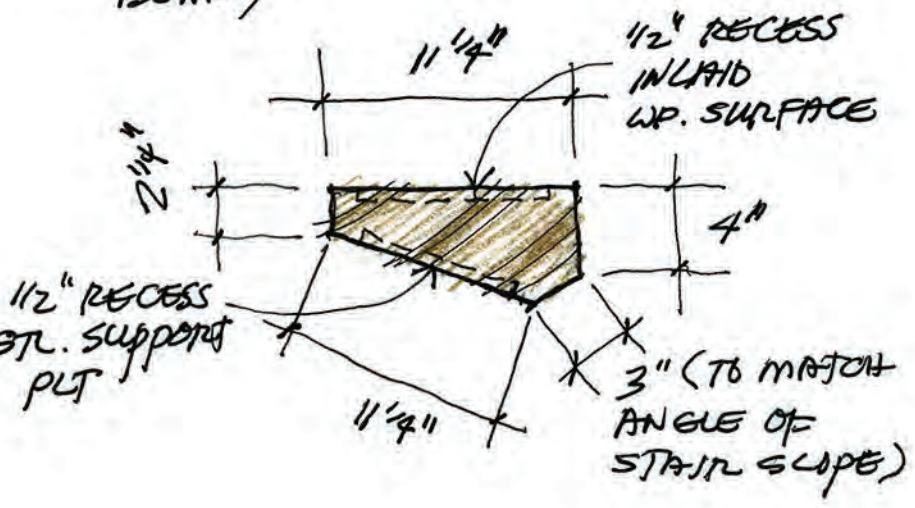
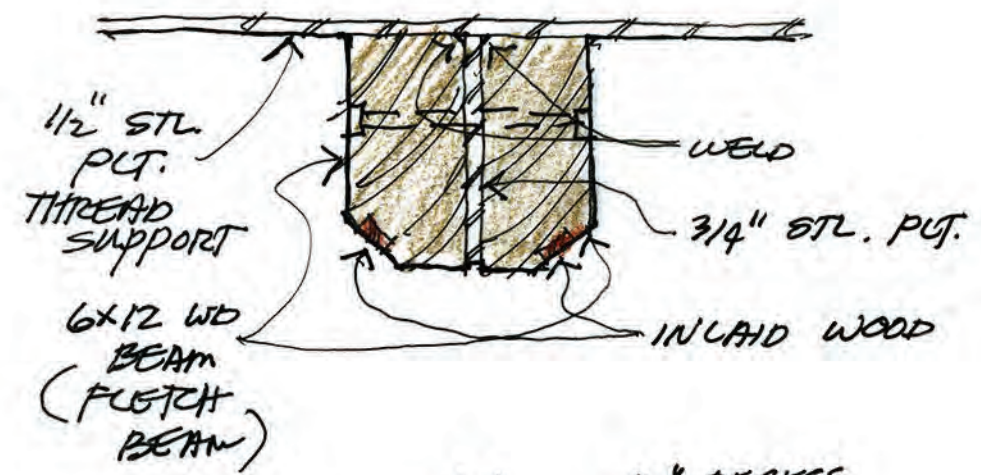



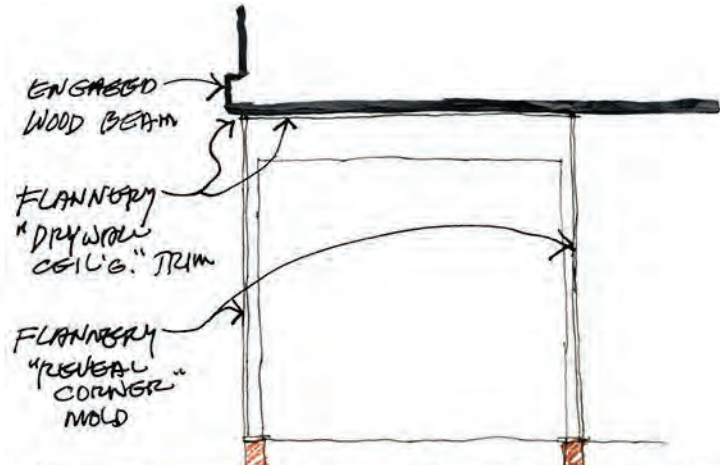
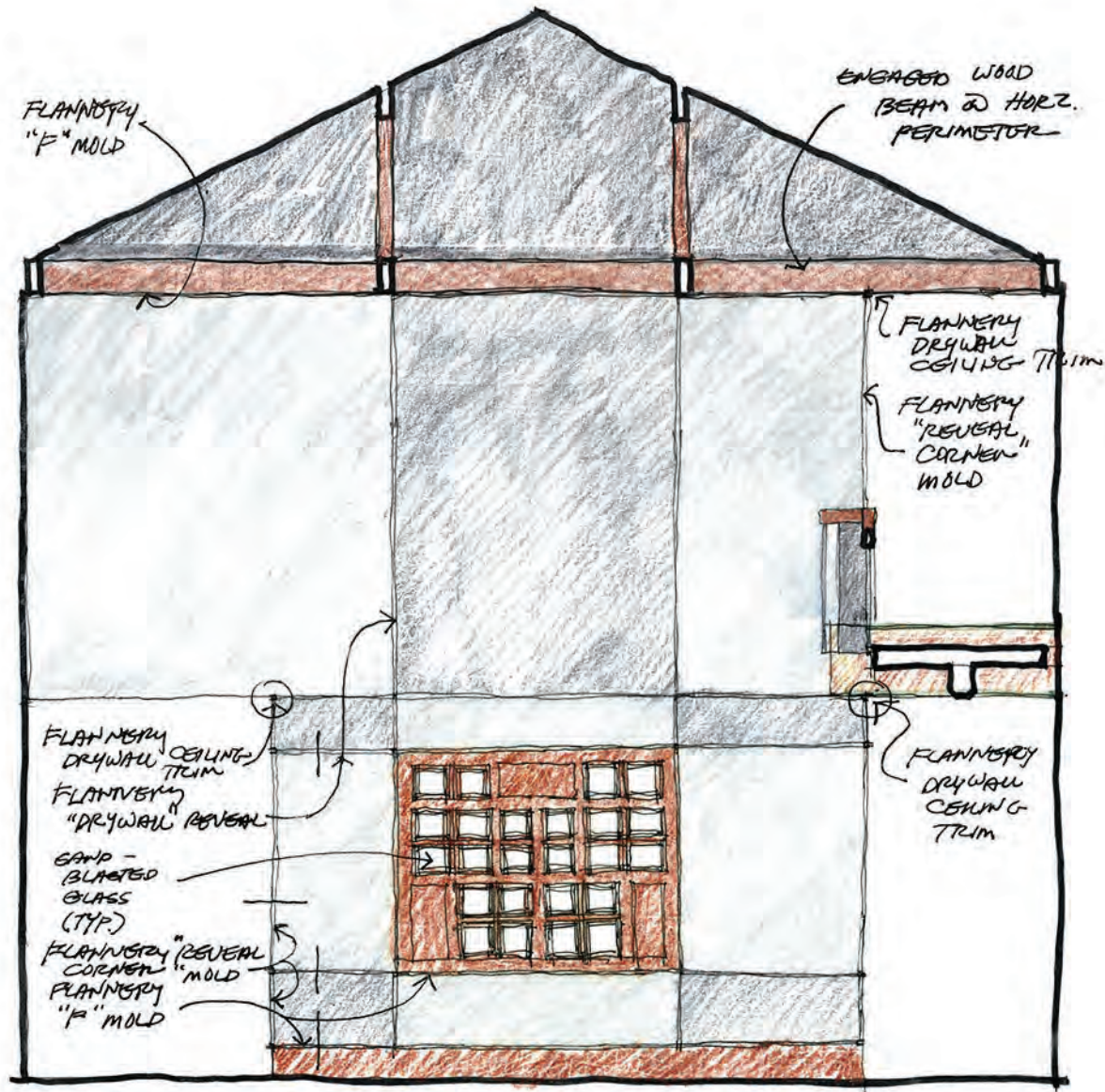



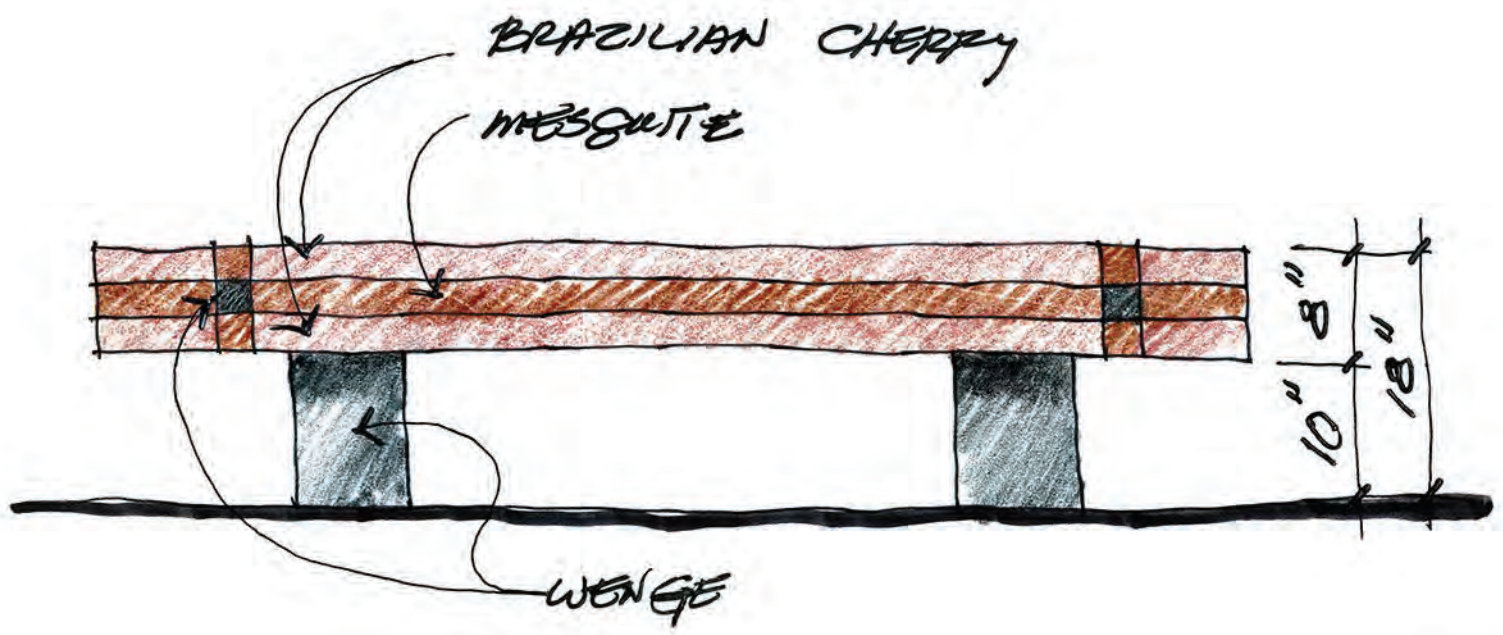
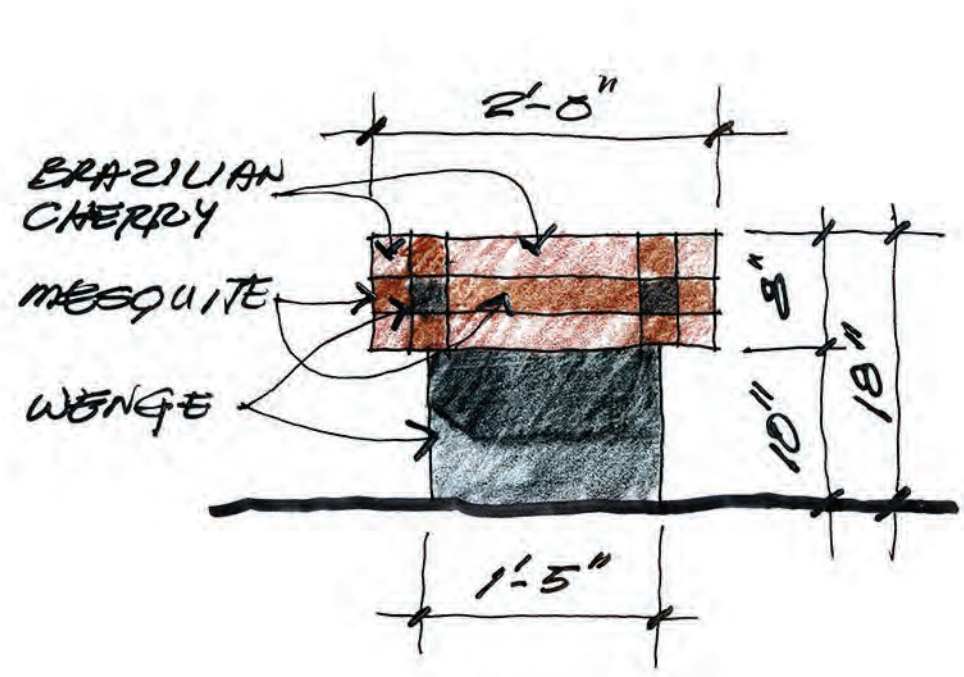
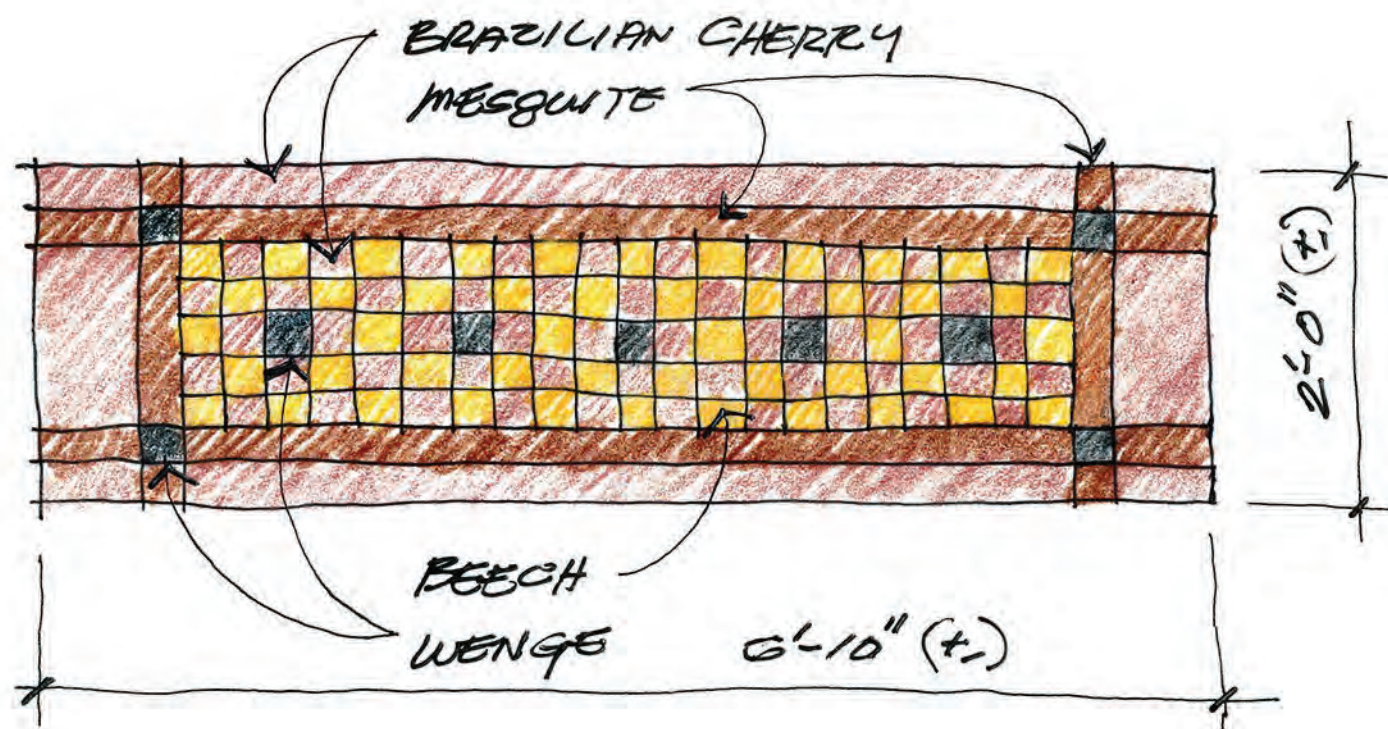



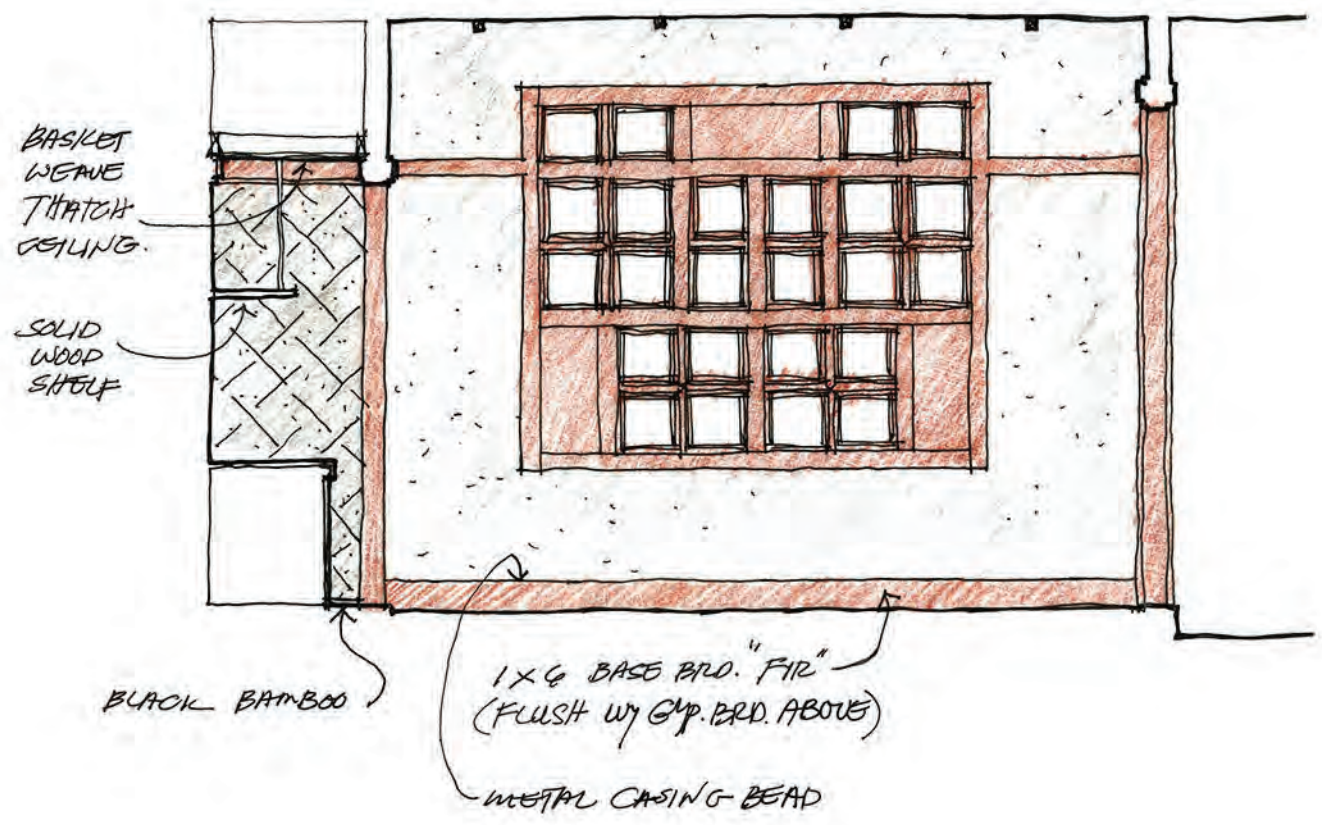
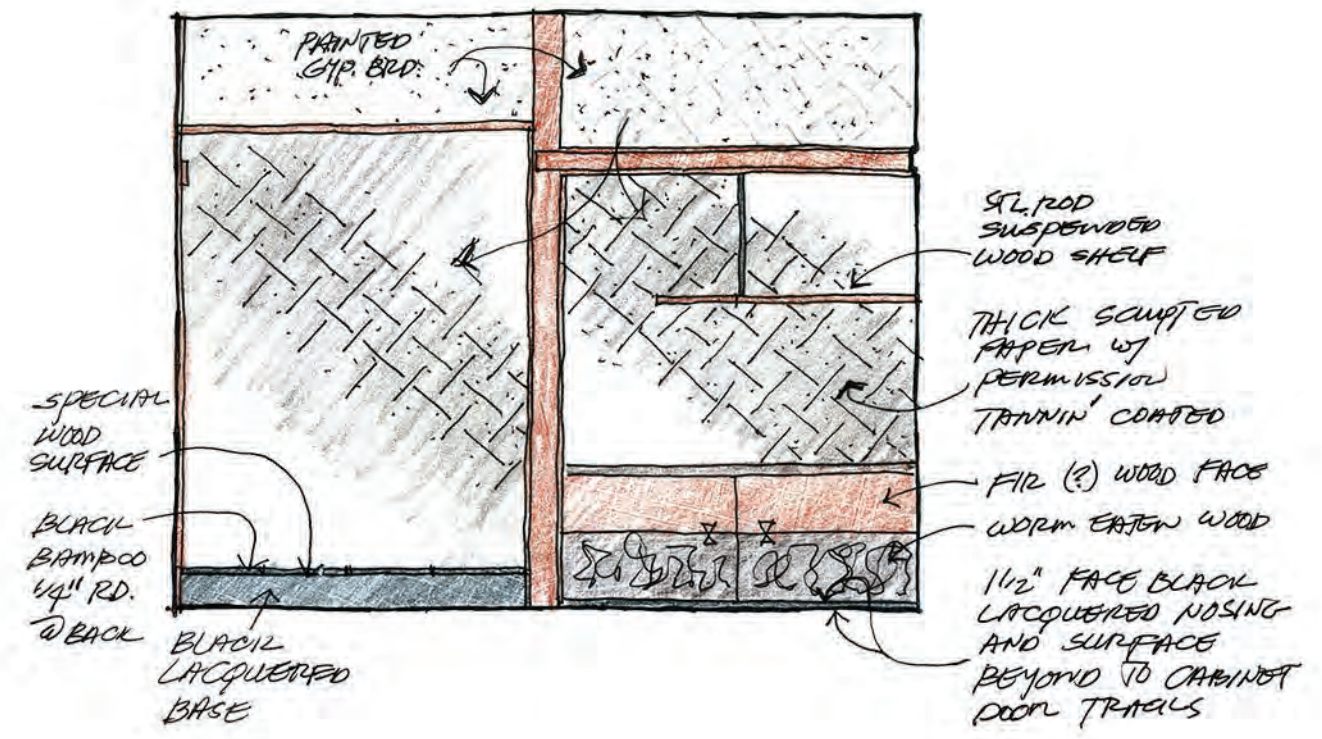
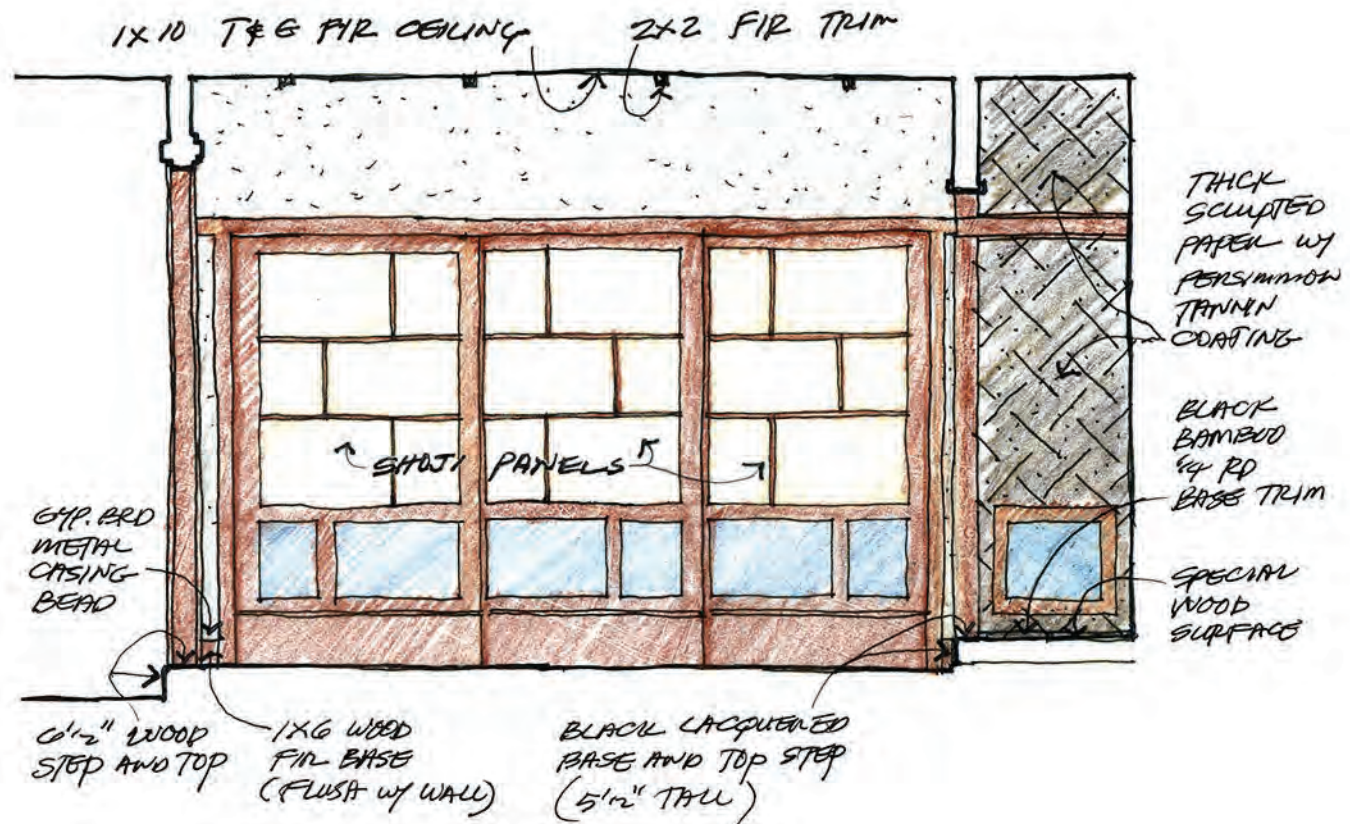



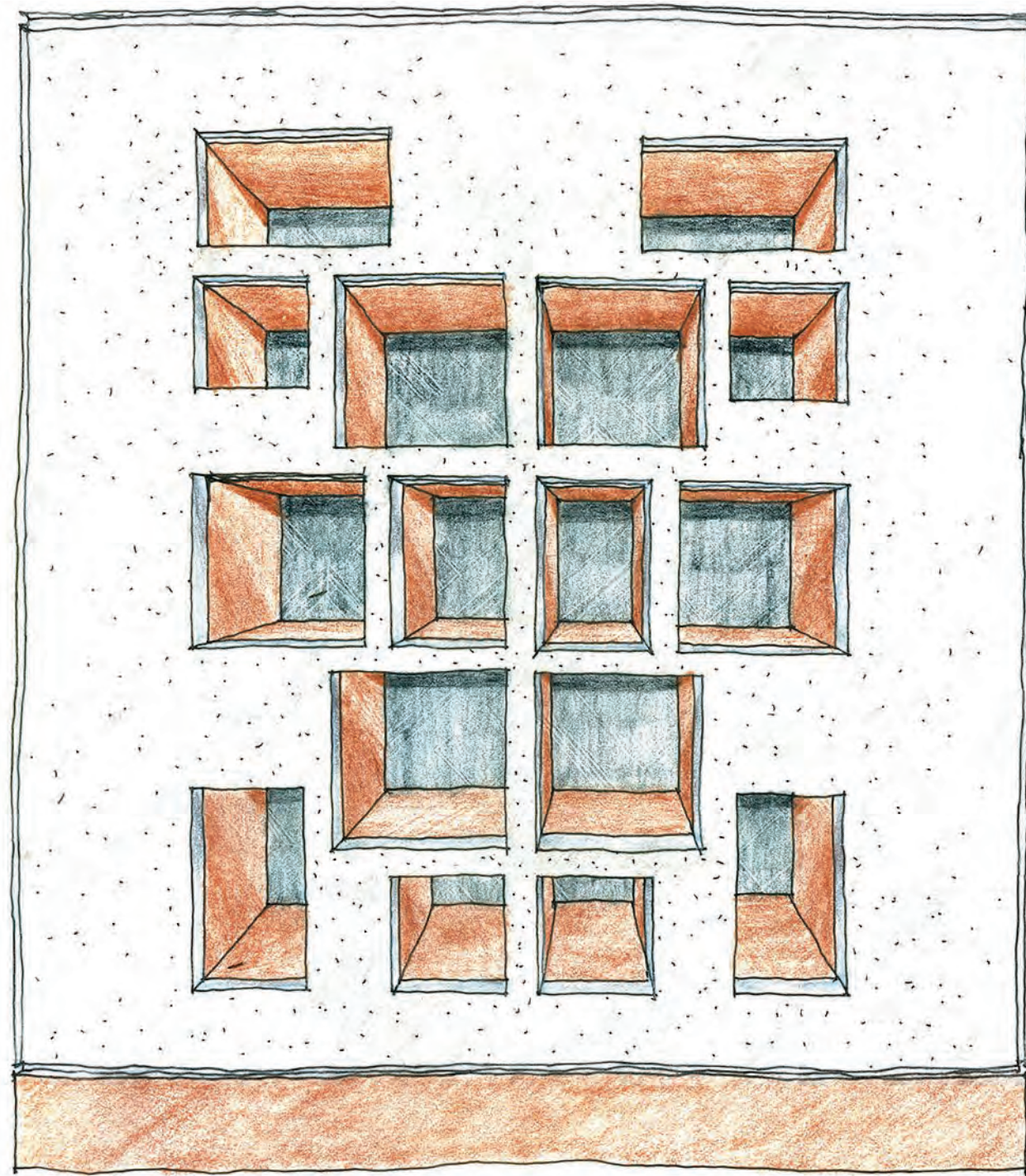





NIX GROUP  
ARCHITECTS





NIX GROUP  
ARCHITECTS



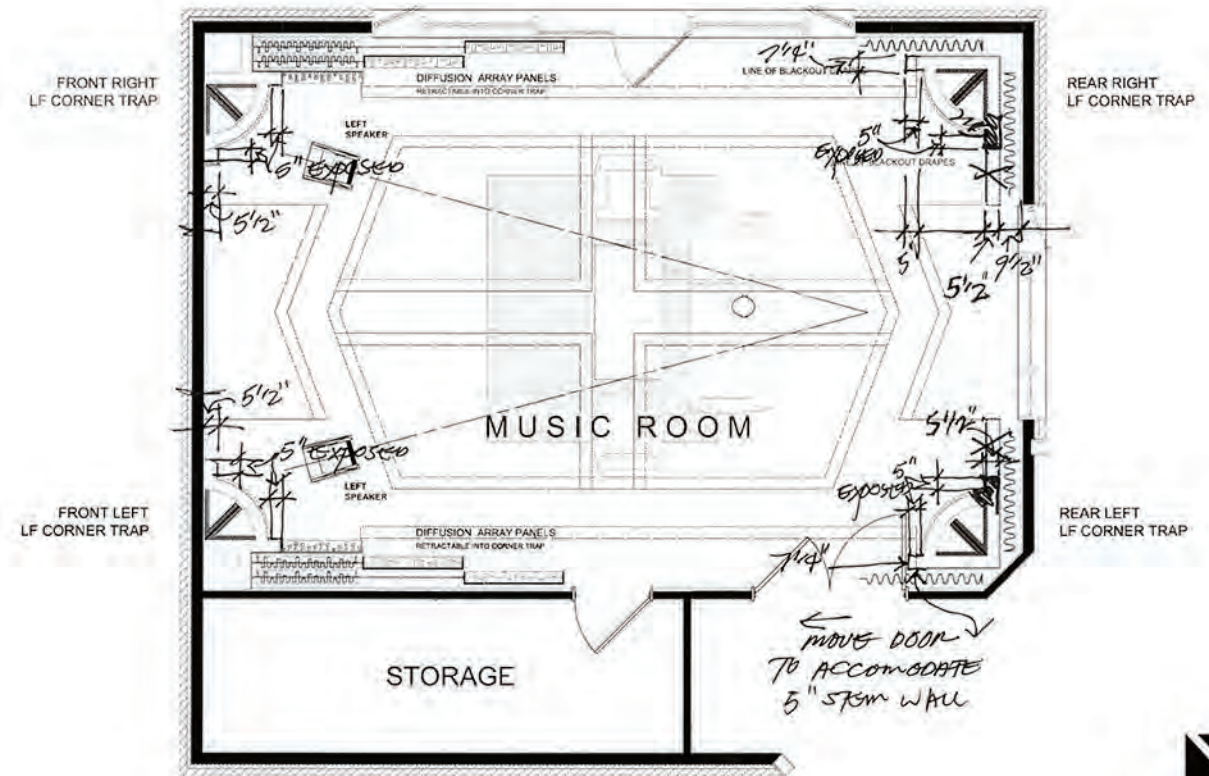
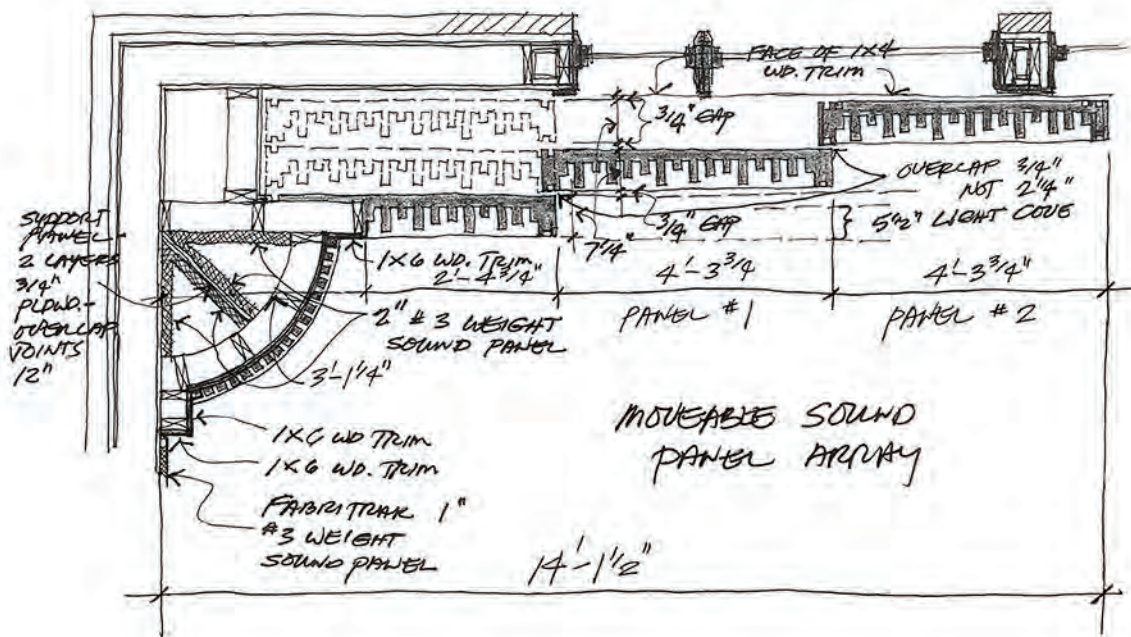
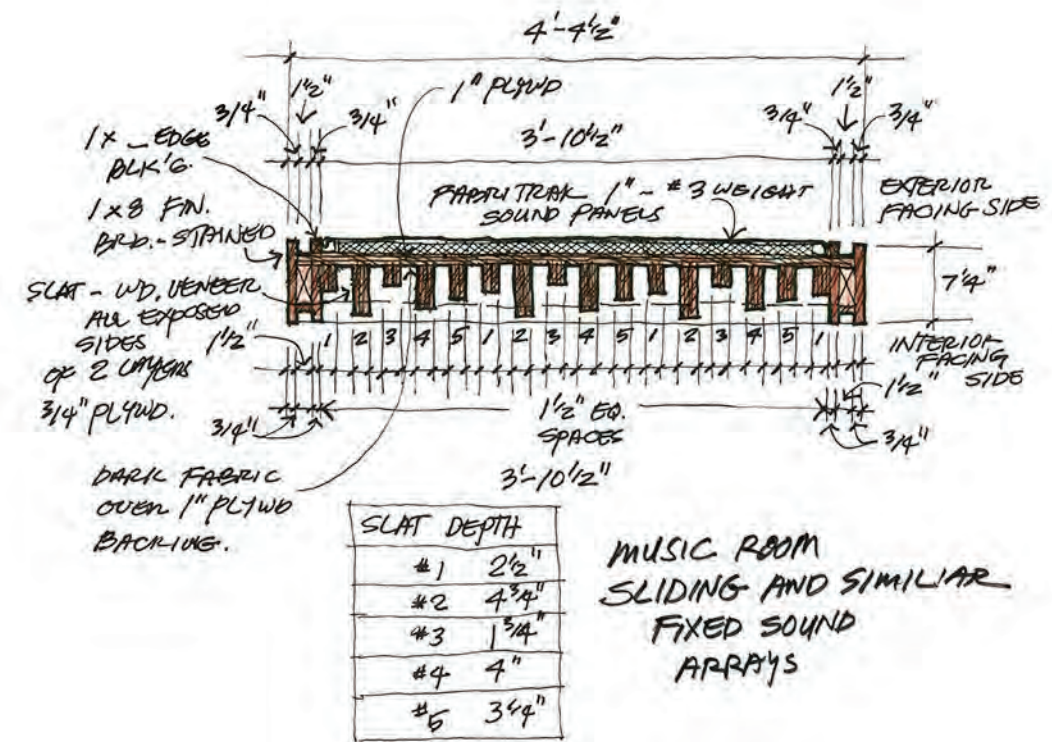
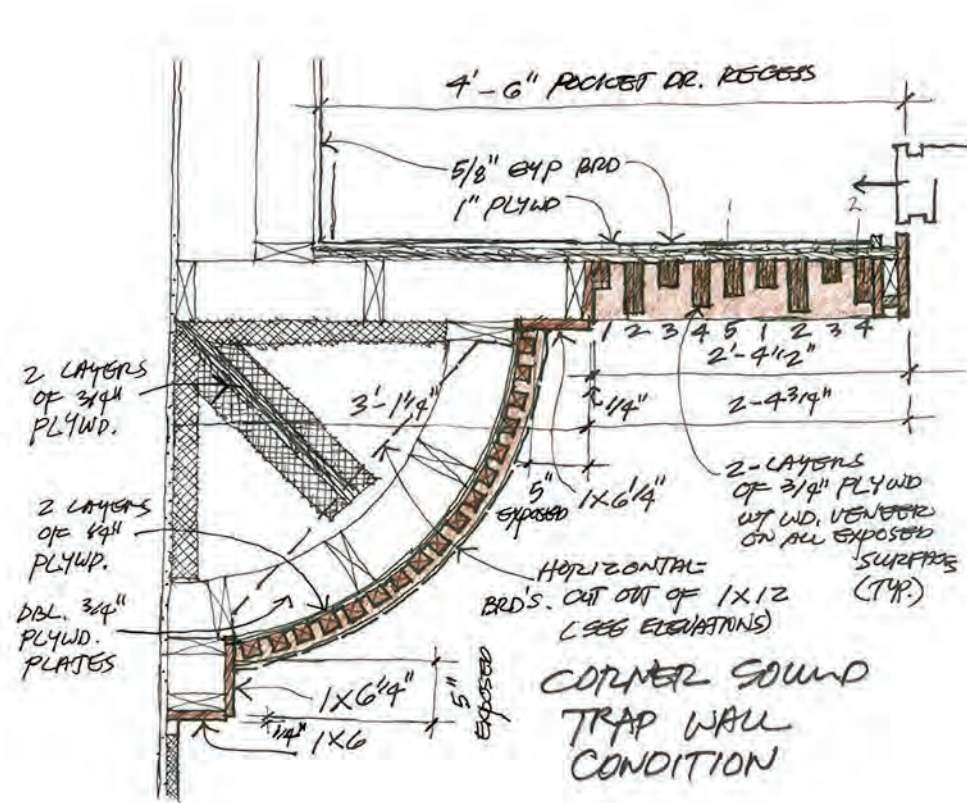



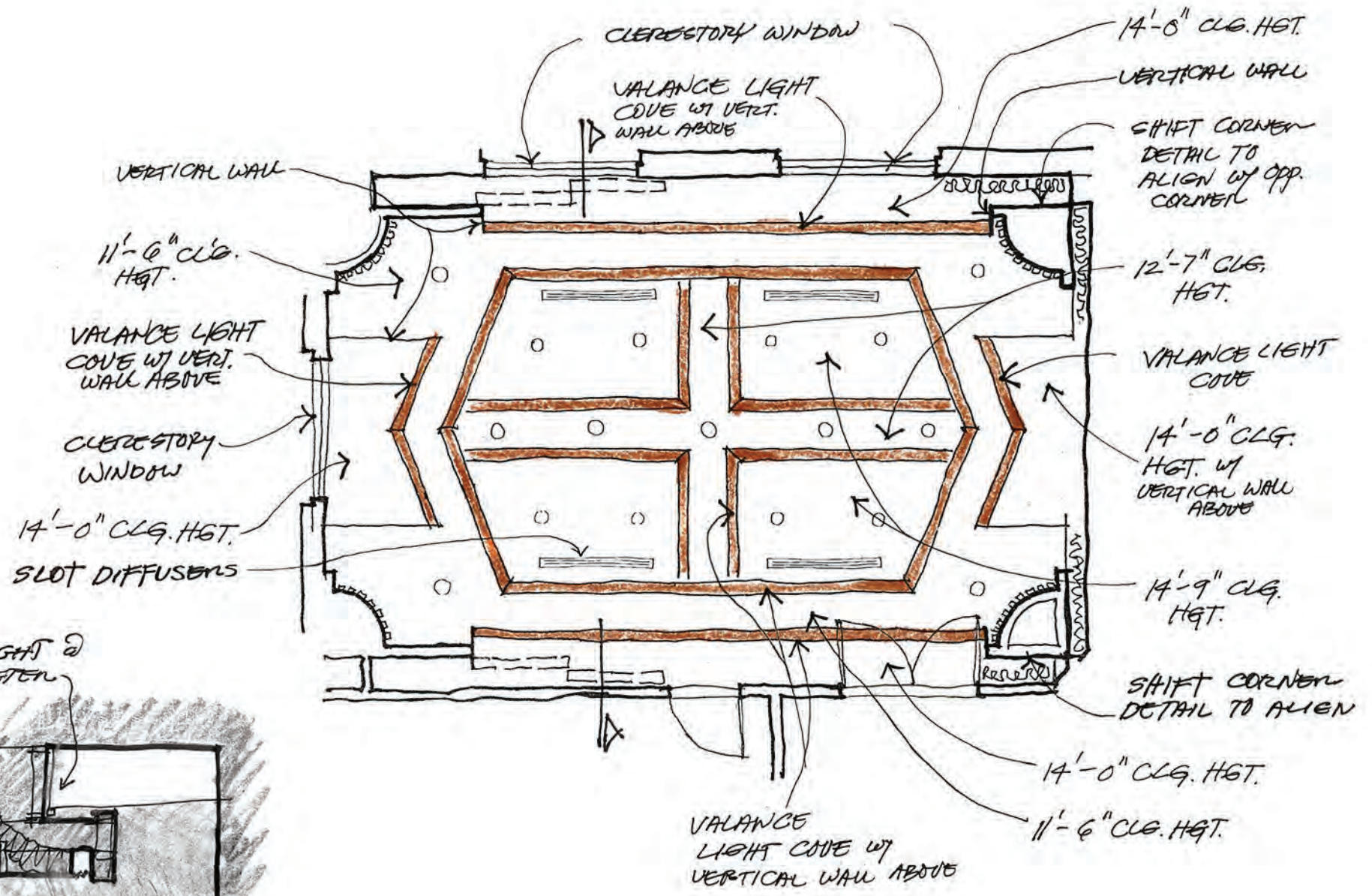
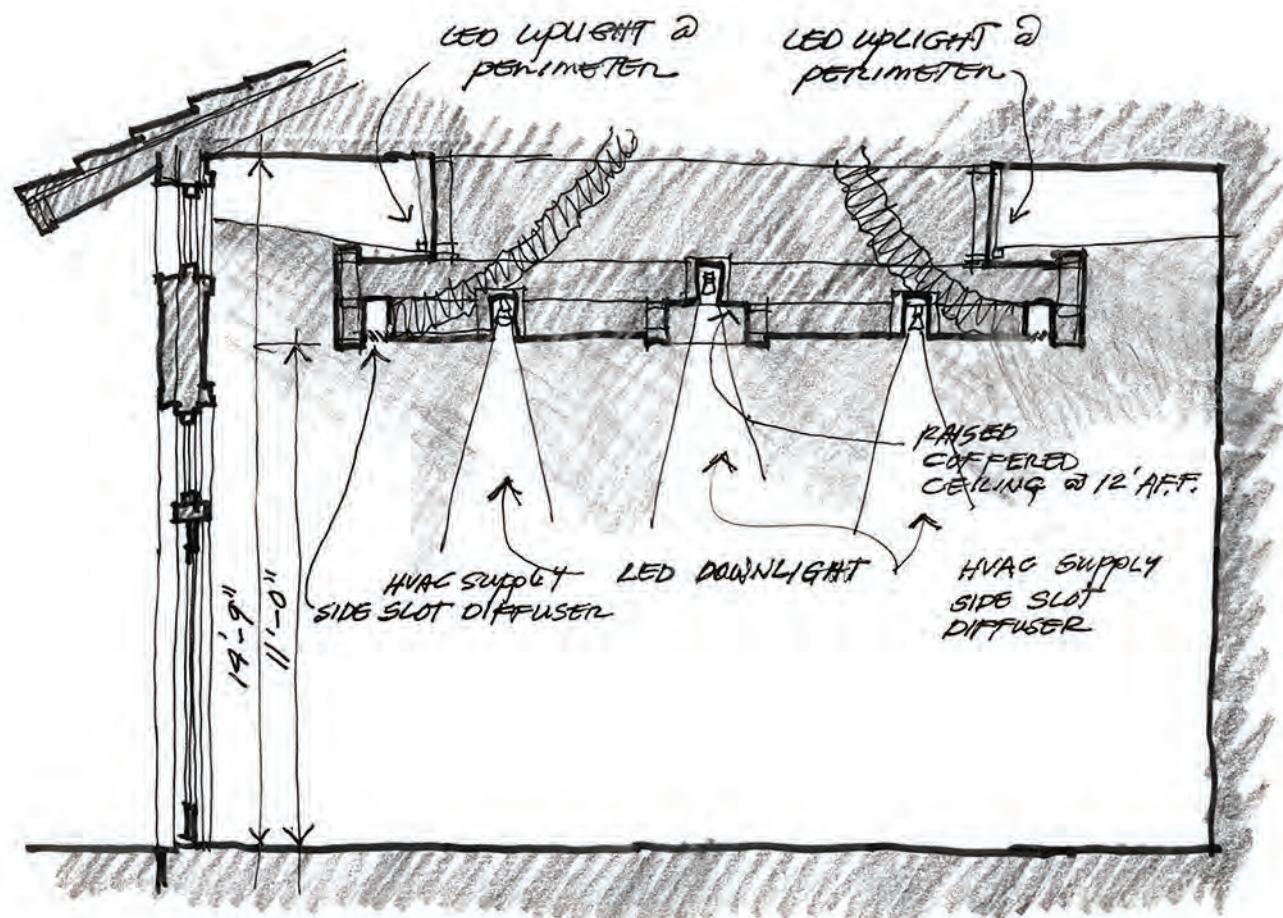



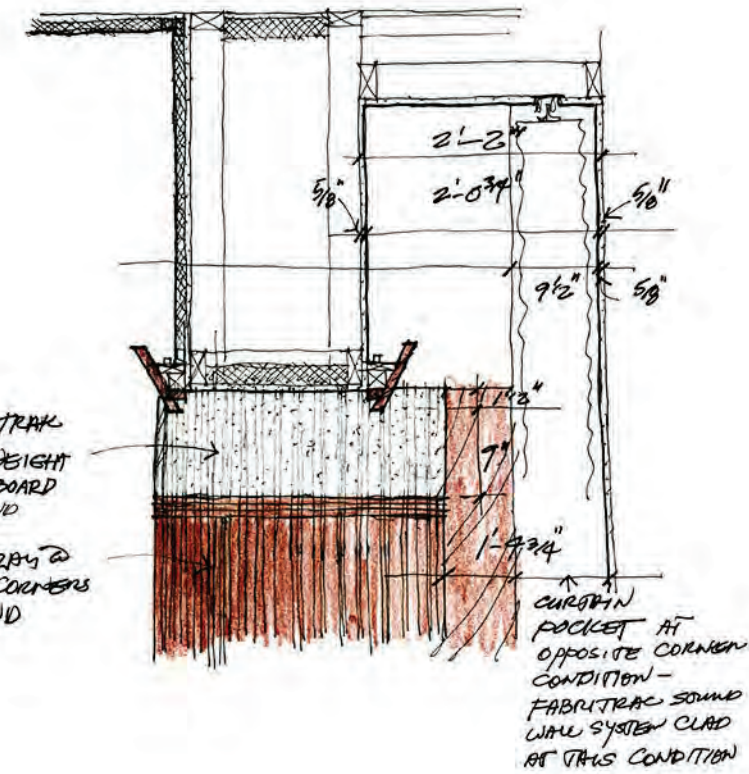
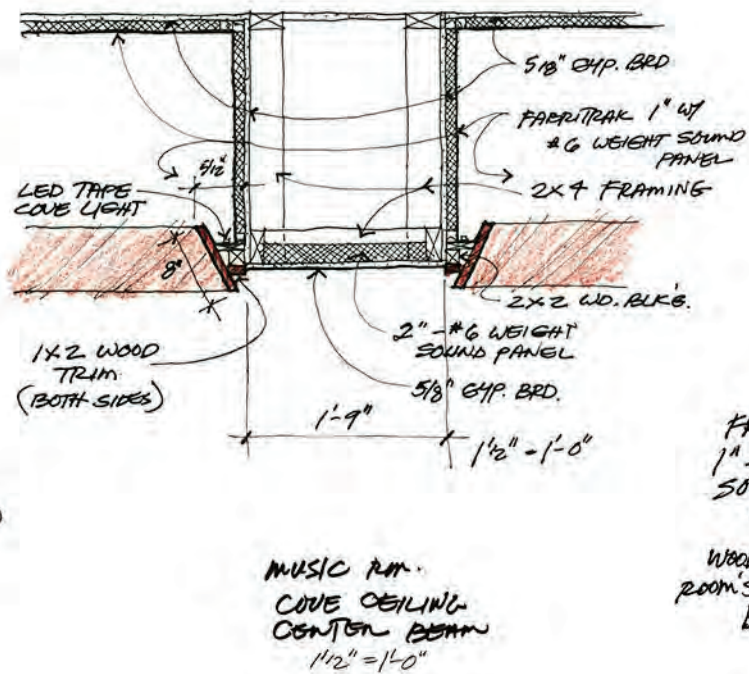
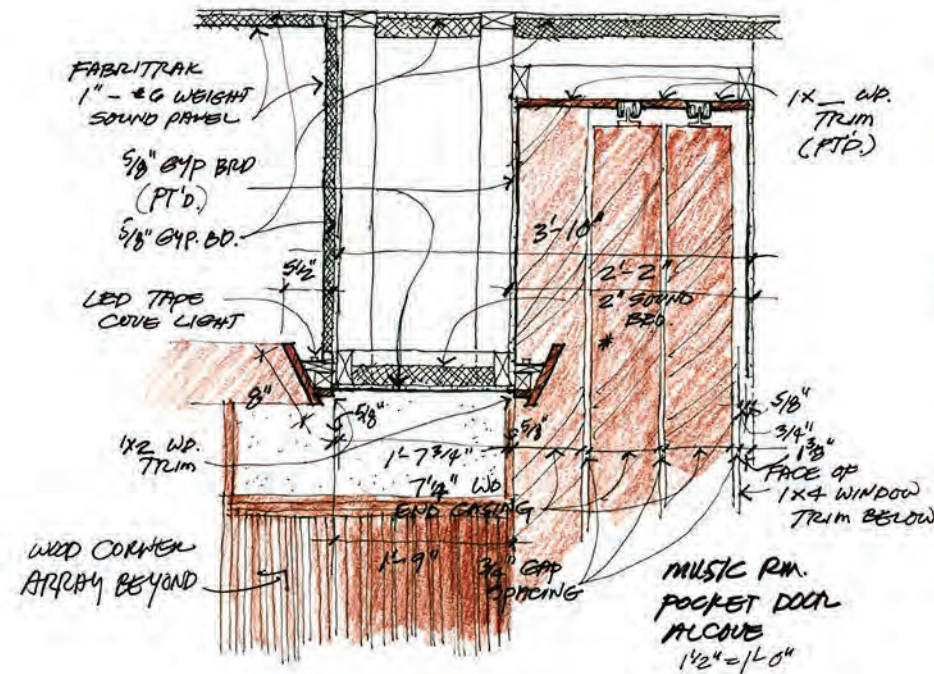

MUSIC ROOM - SEPARATE PANELS  
REAR VIEW OF SLIDING PANEL  
CREATED BY RECESS

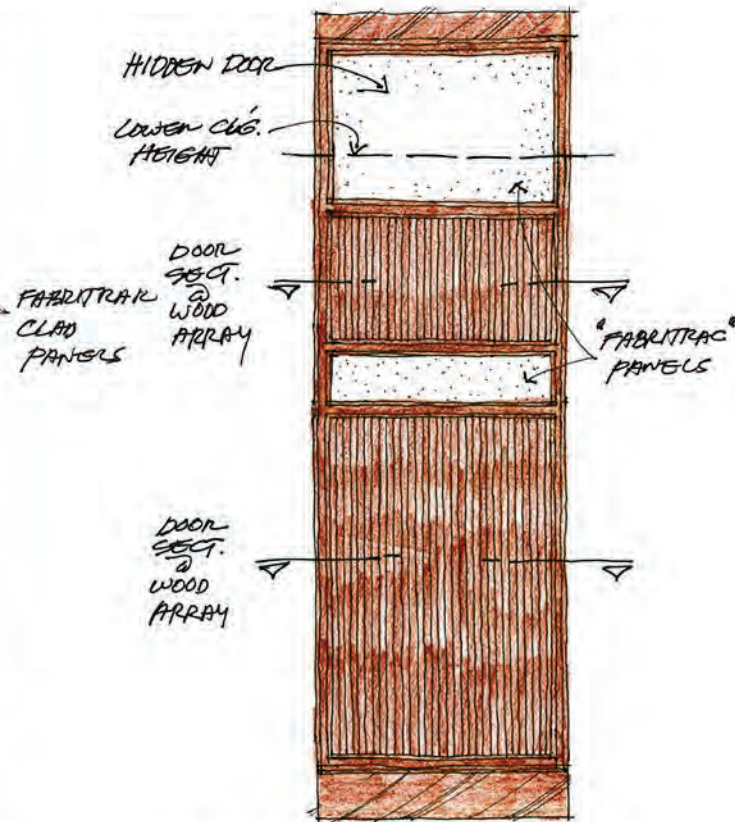

MUSIC ROOM - SEPARATE PANELS  
FRONT VIEW OF SLIDING PANEL  
CREATED BY RECESS

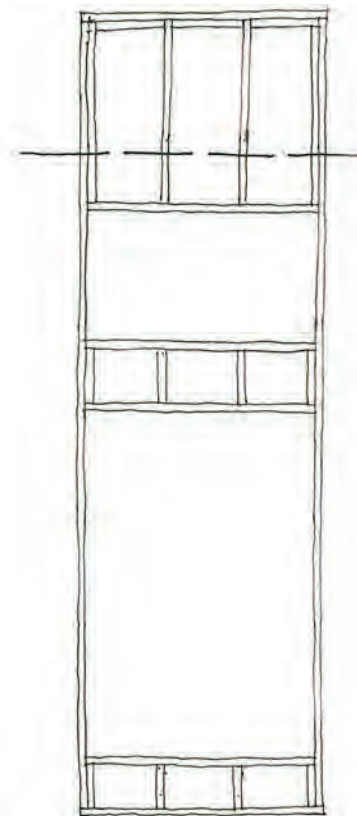

MUSIC ROOM - DESIGN TO STIFFEN  
VIEW OF 2X4 DOOR TO PREVENT  
HIDDEN FRAME RACKING



ALTERNATE CONTINUOUS EDGE  
MUSIC ROOM - RECESS DESIGN  
REAR VIEW OF SLIDING PANEL





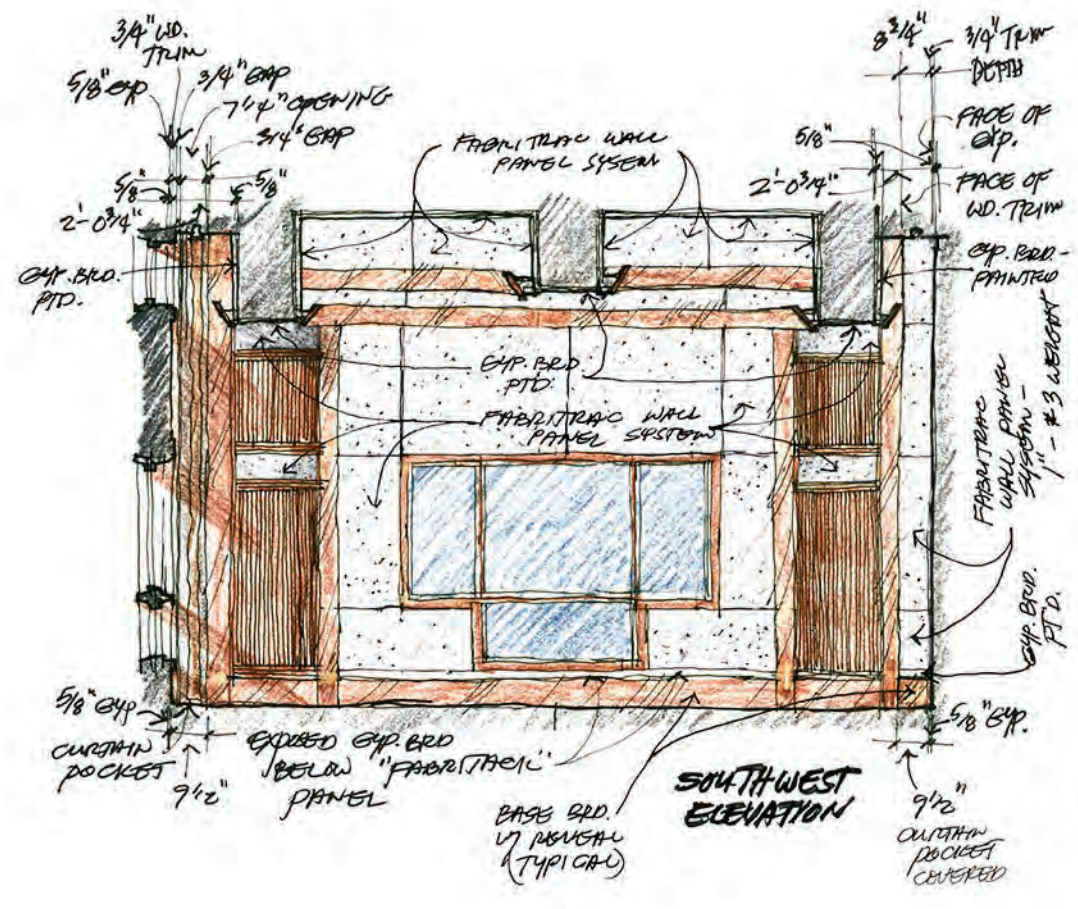
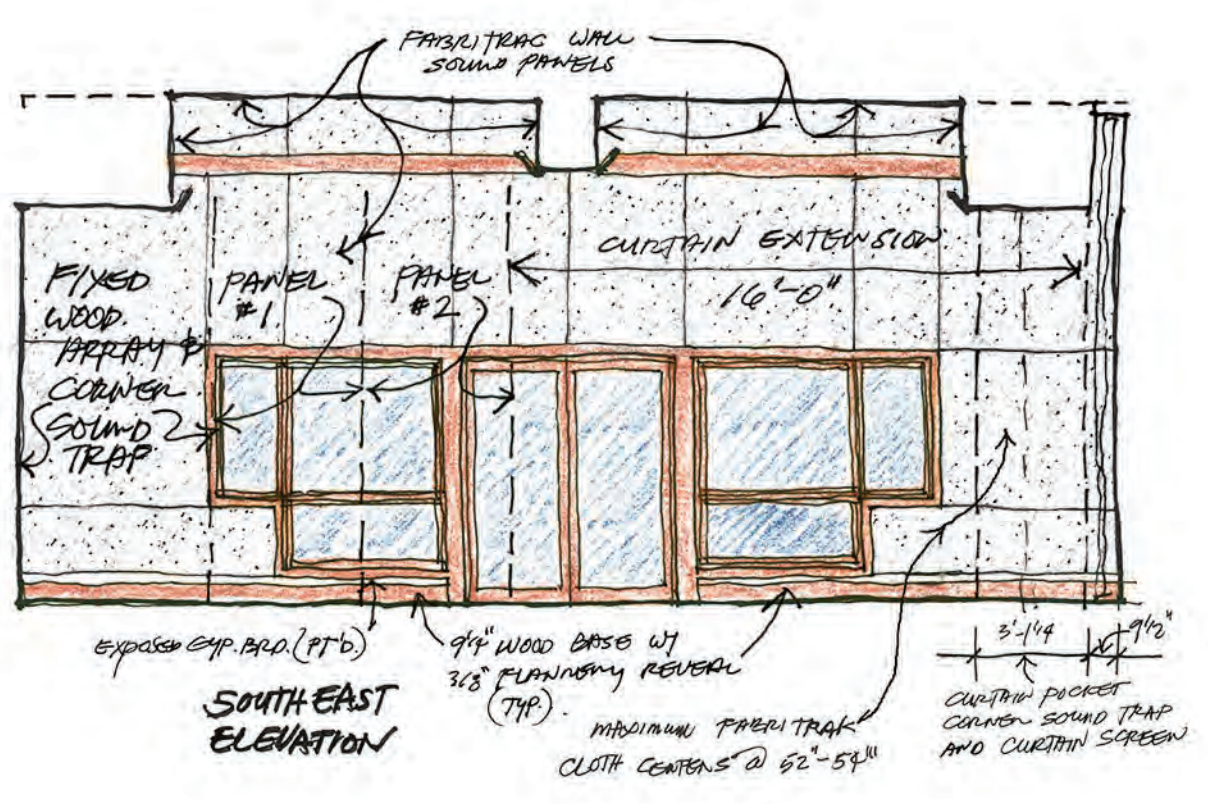
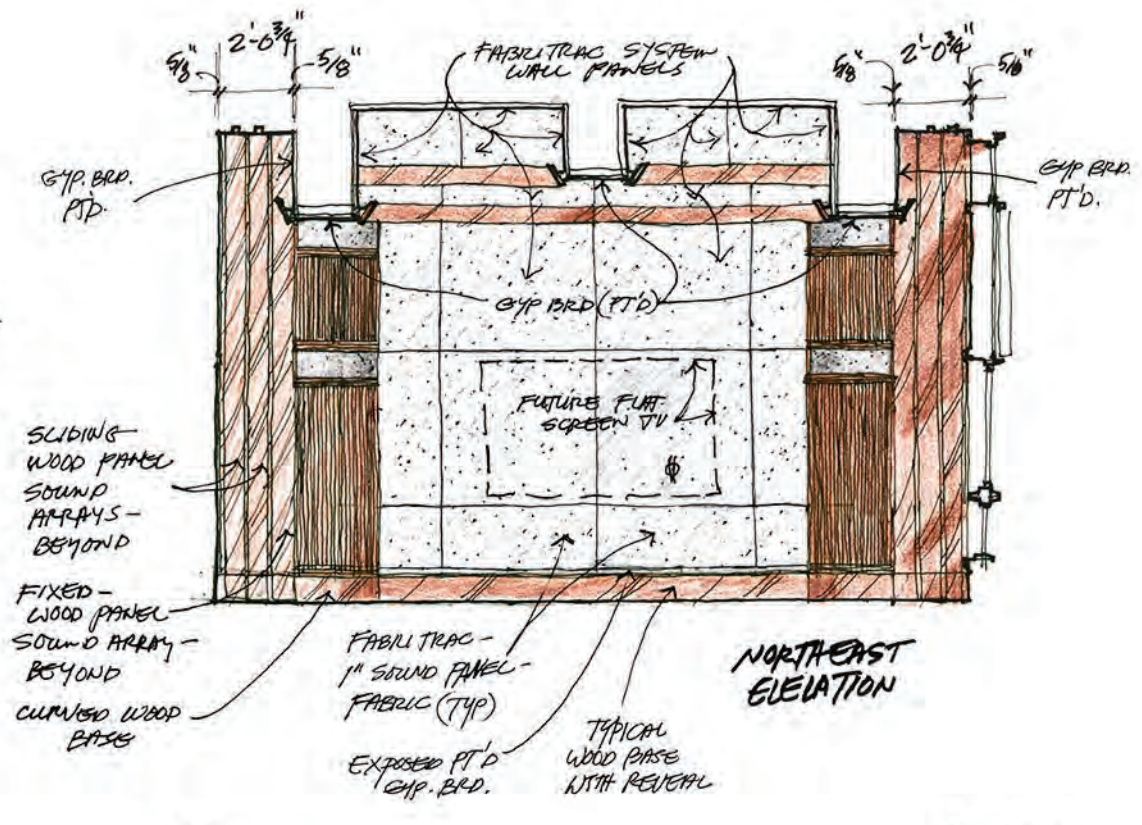
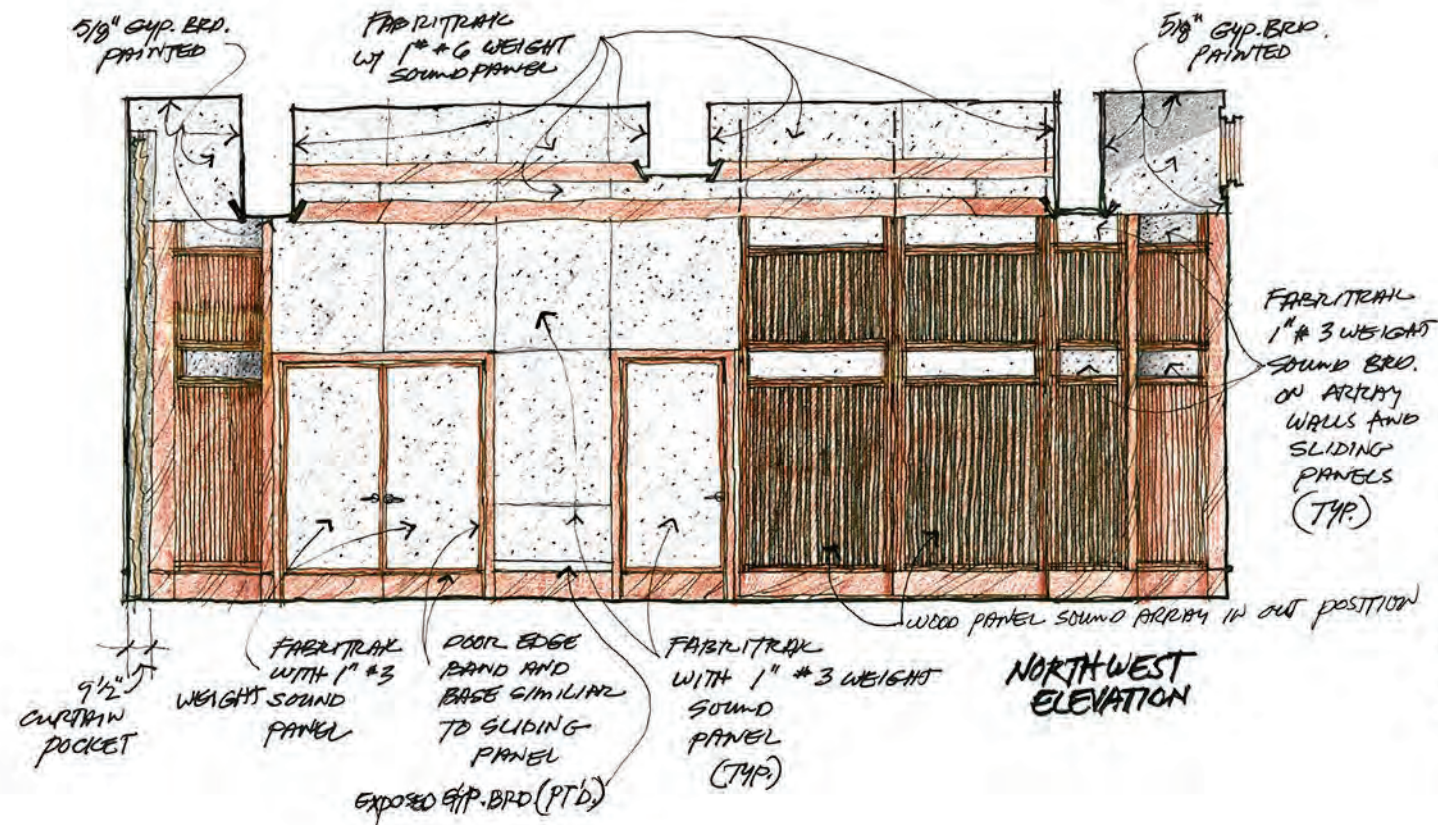



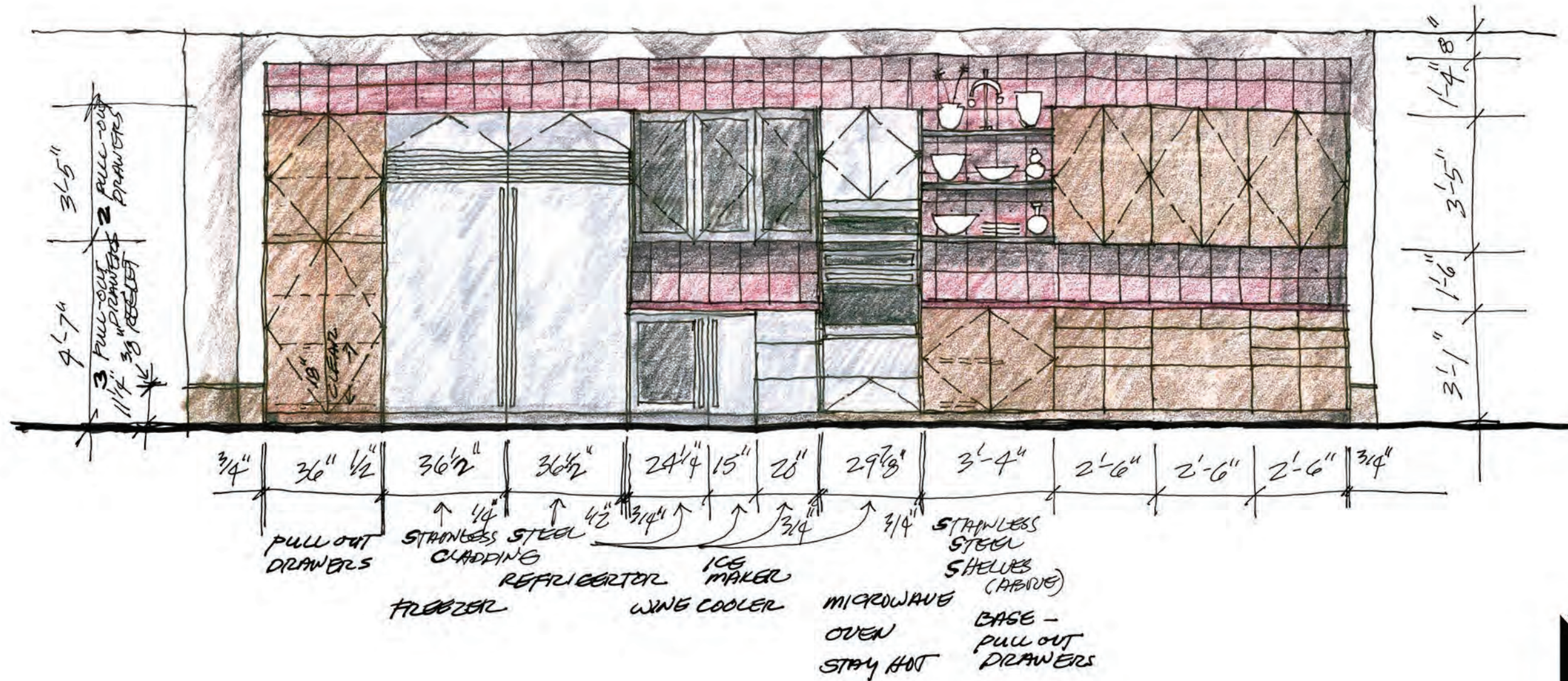
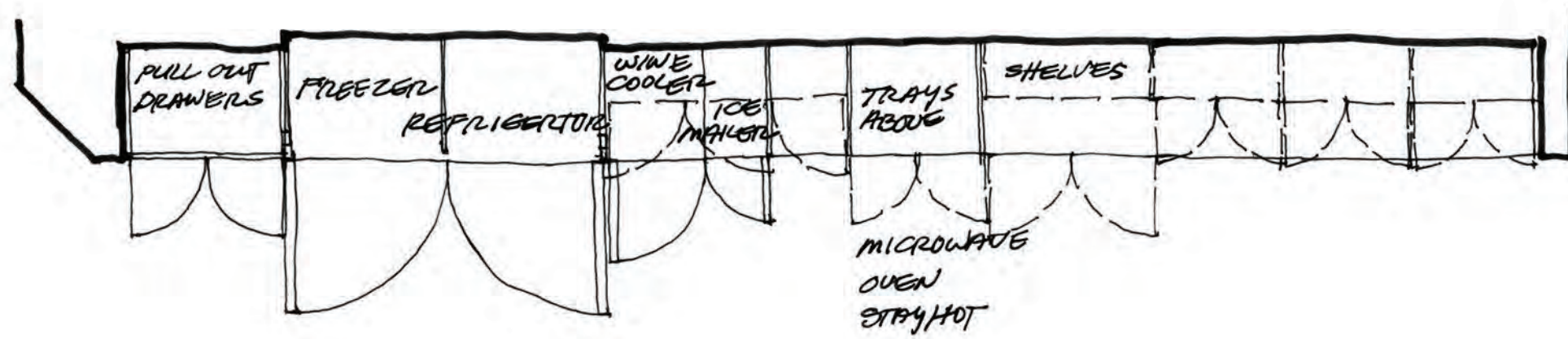





WOOD SPECIES #5

OPTION #1 - ALL OPEN CABINETS' BACK PANELS - WOOD SPECIES #4

OPTION #1 - ALL OPEN CABINETS' BACK PANELS - WOOD SPECIES #4

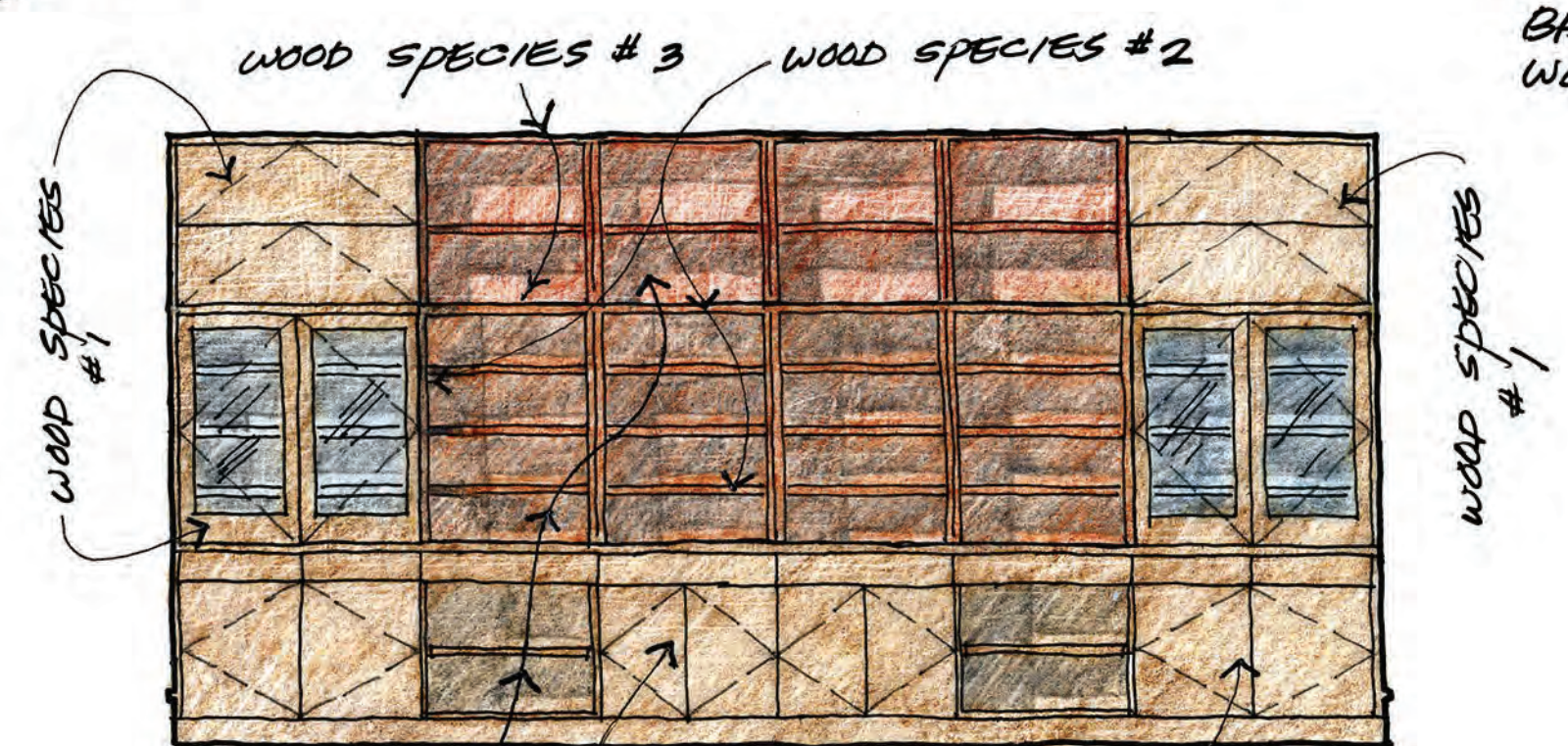

OPTION #1 - ALL OPEN CABINETS' BACK PANELS WOOD SPECIES #4



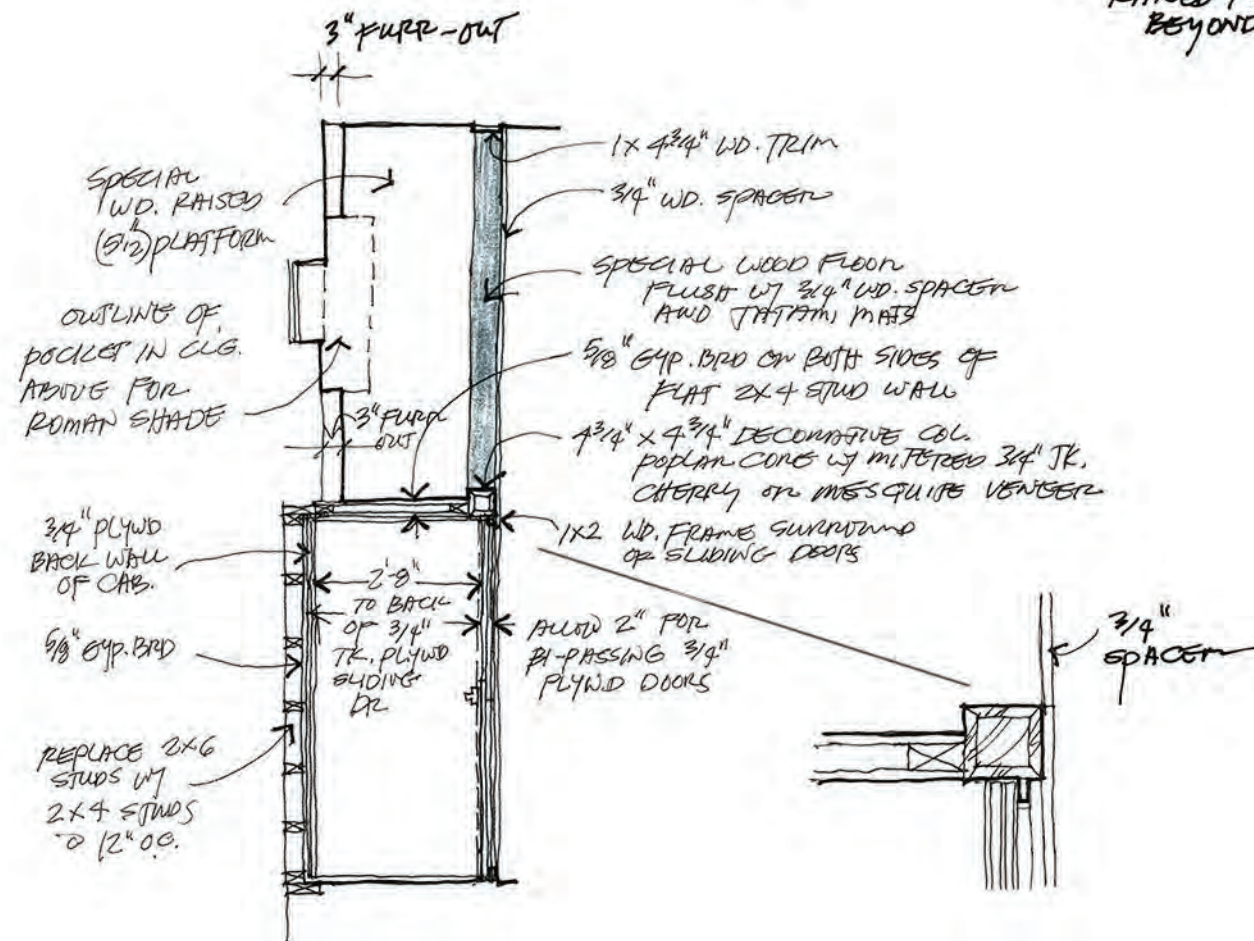
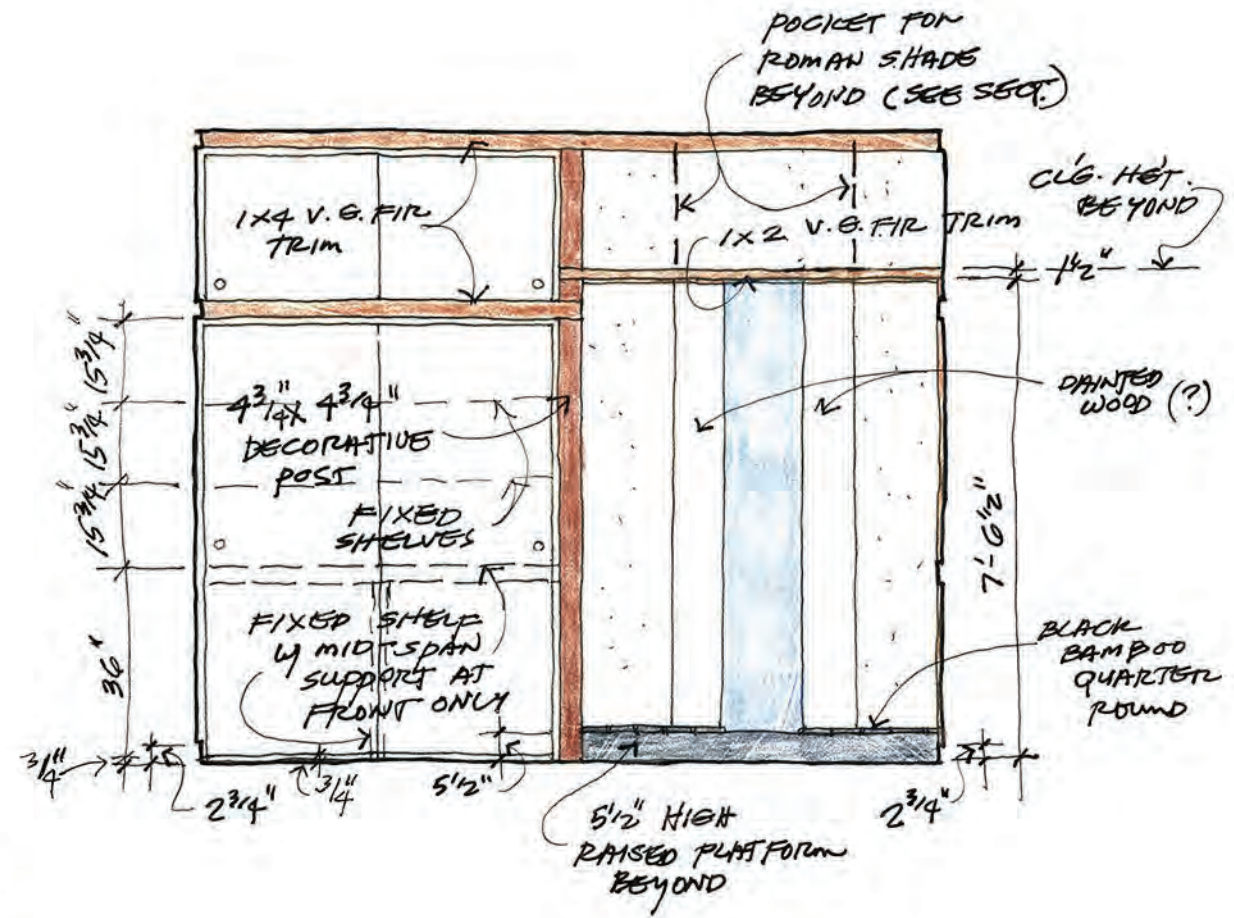
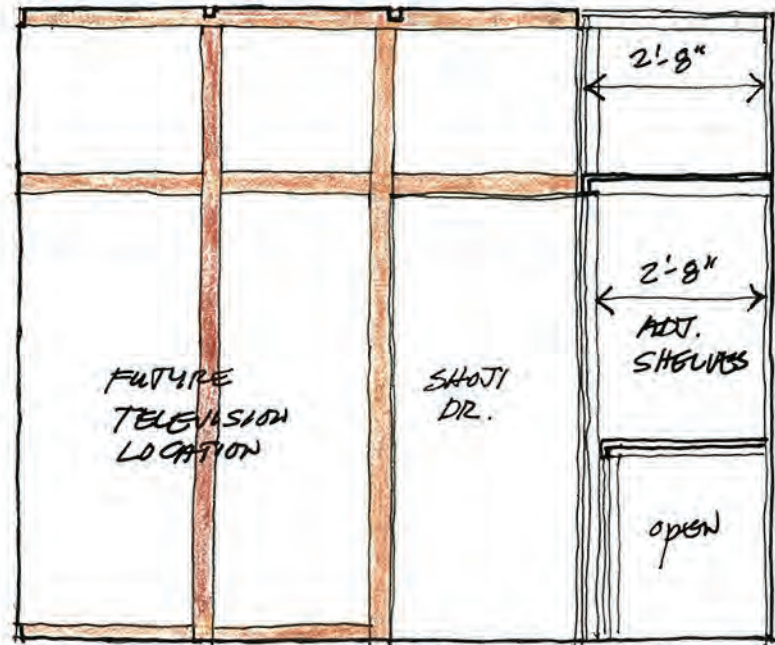



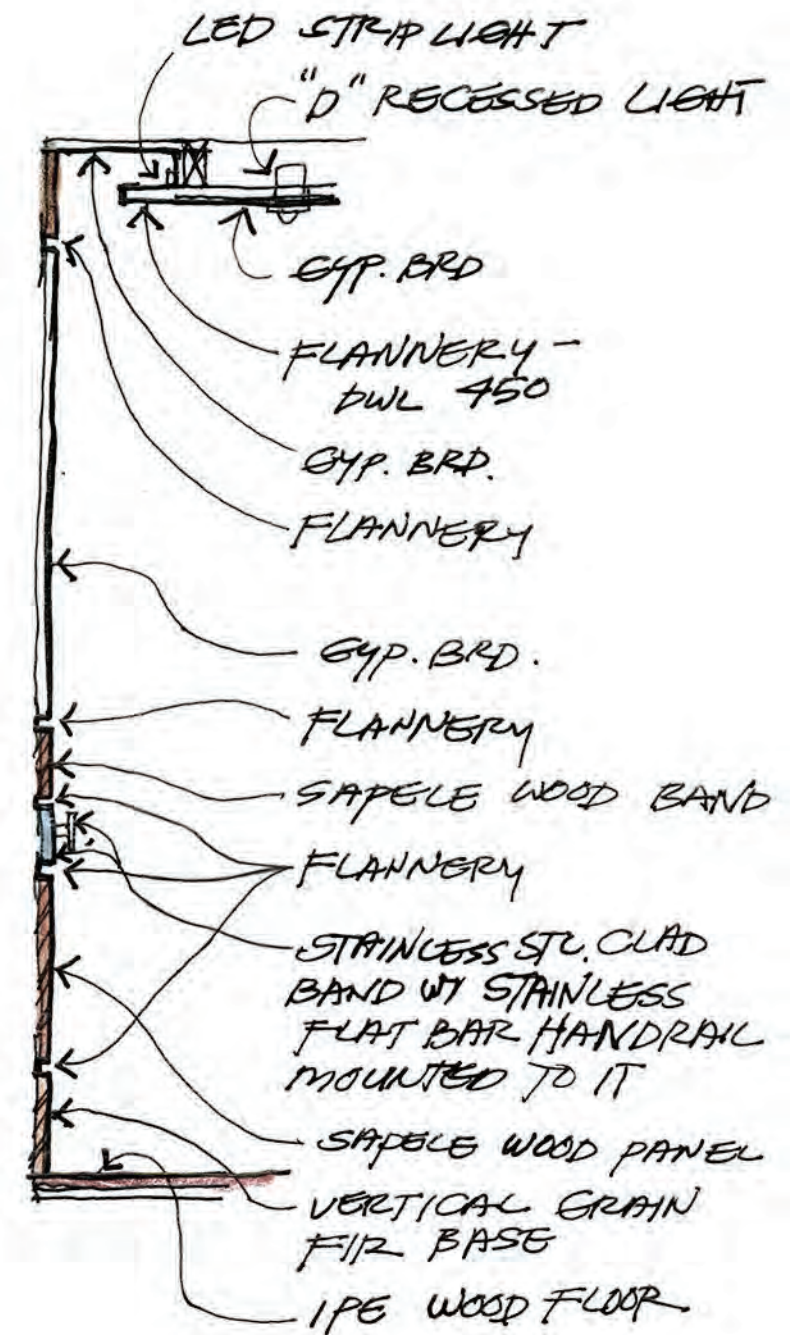
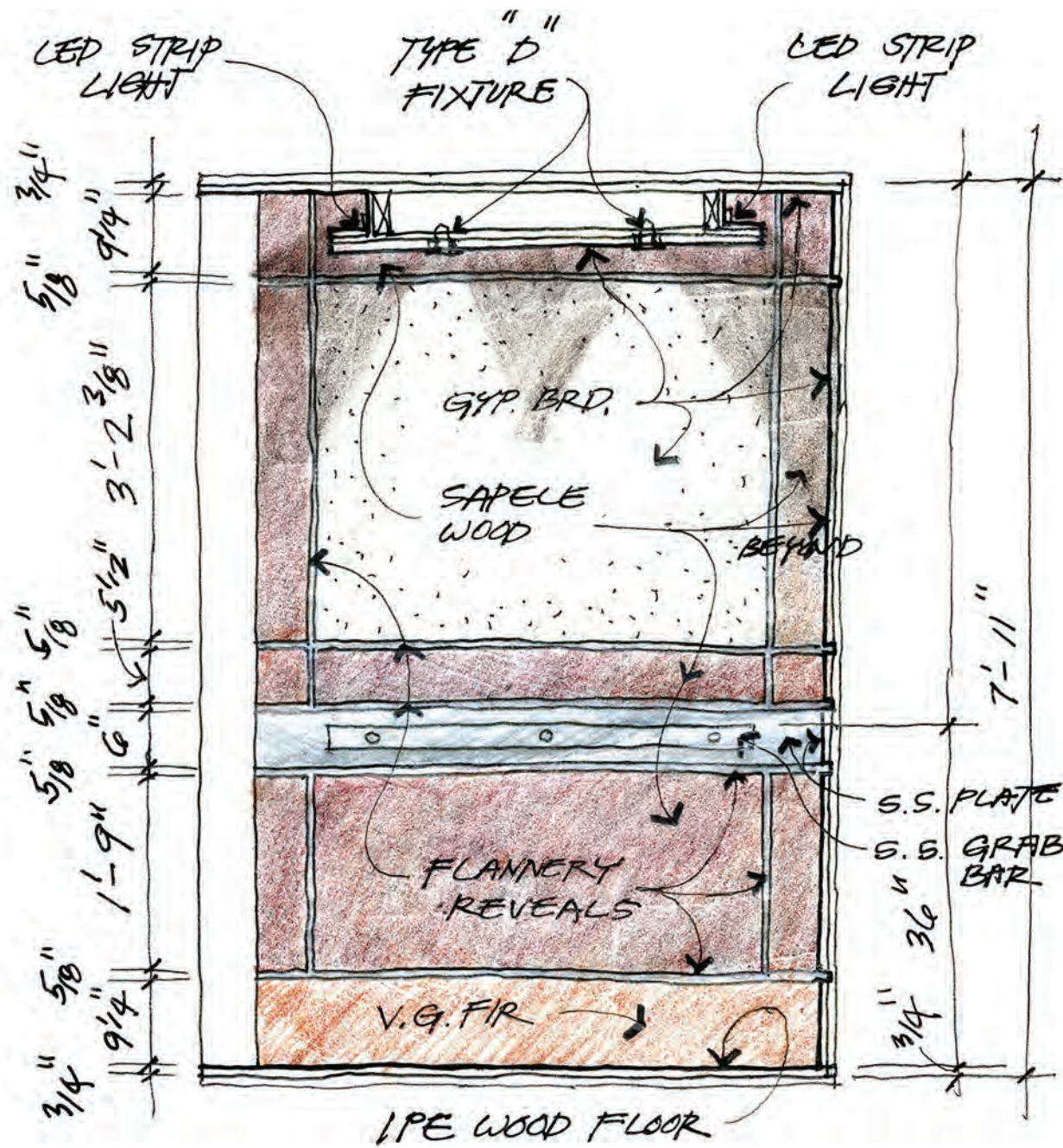



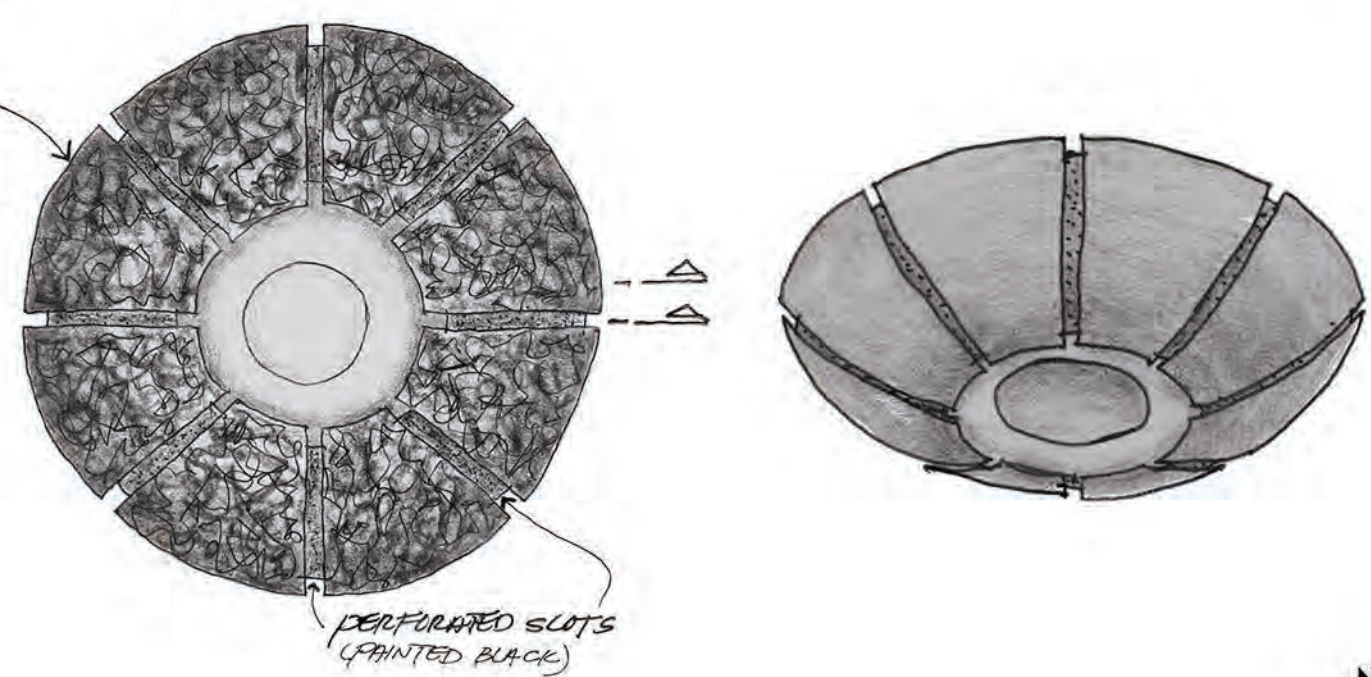
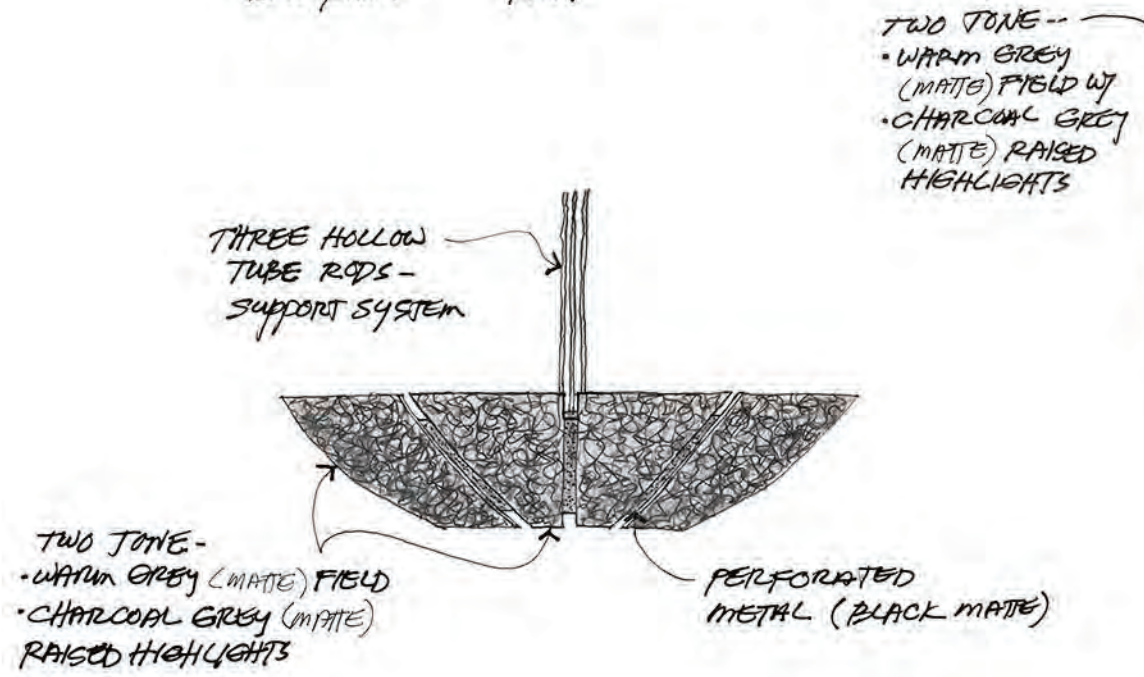
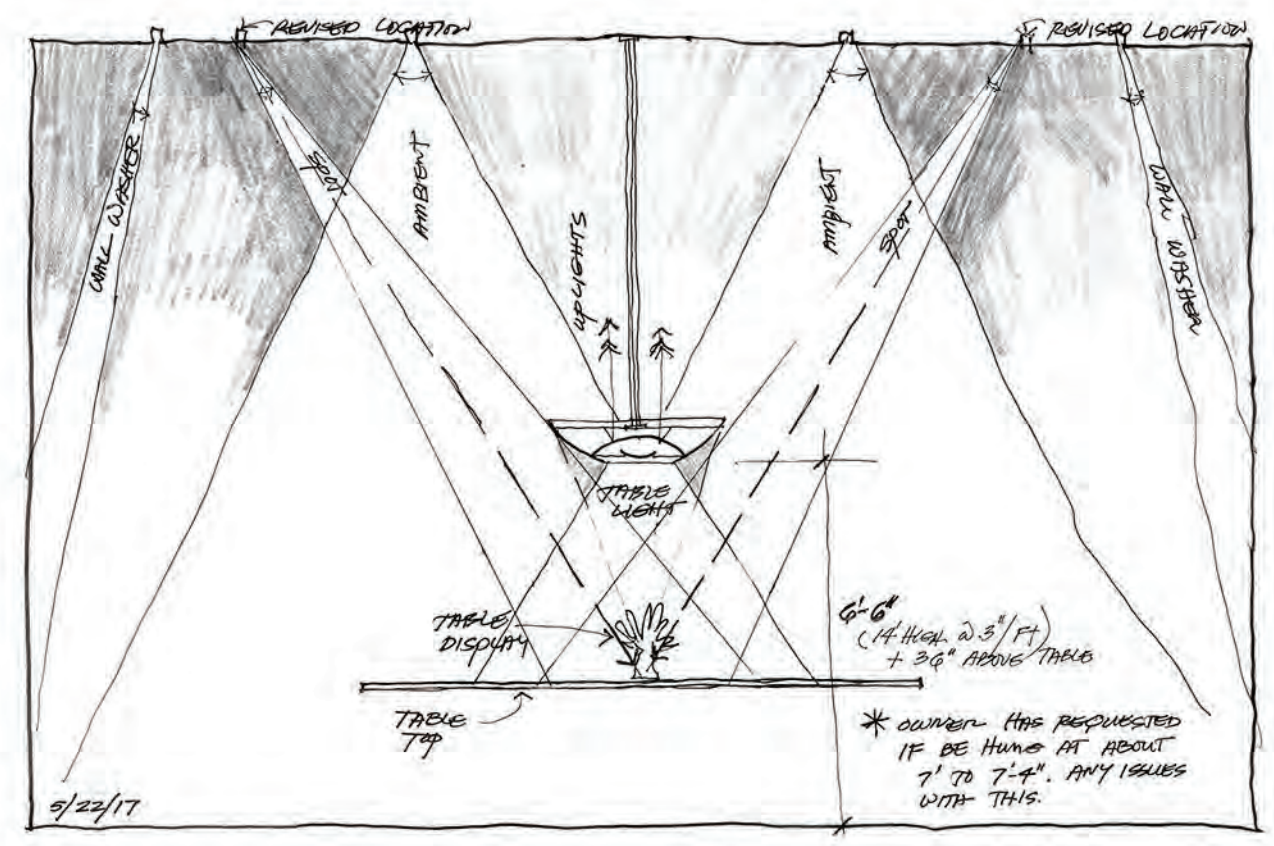
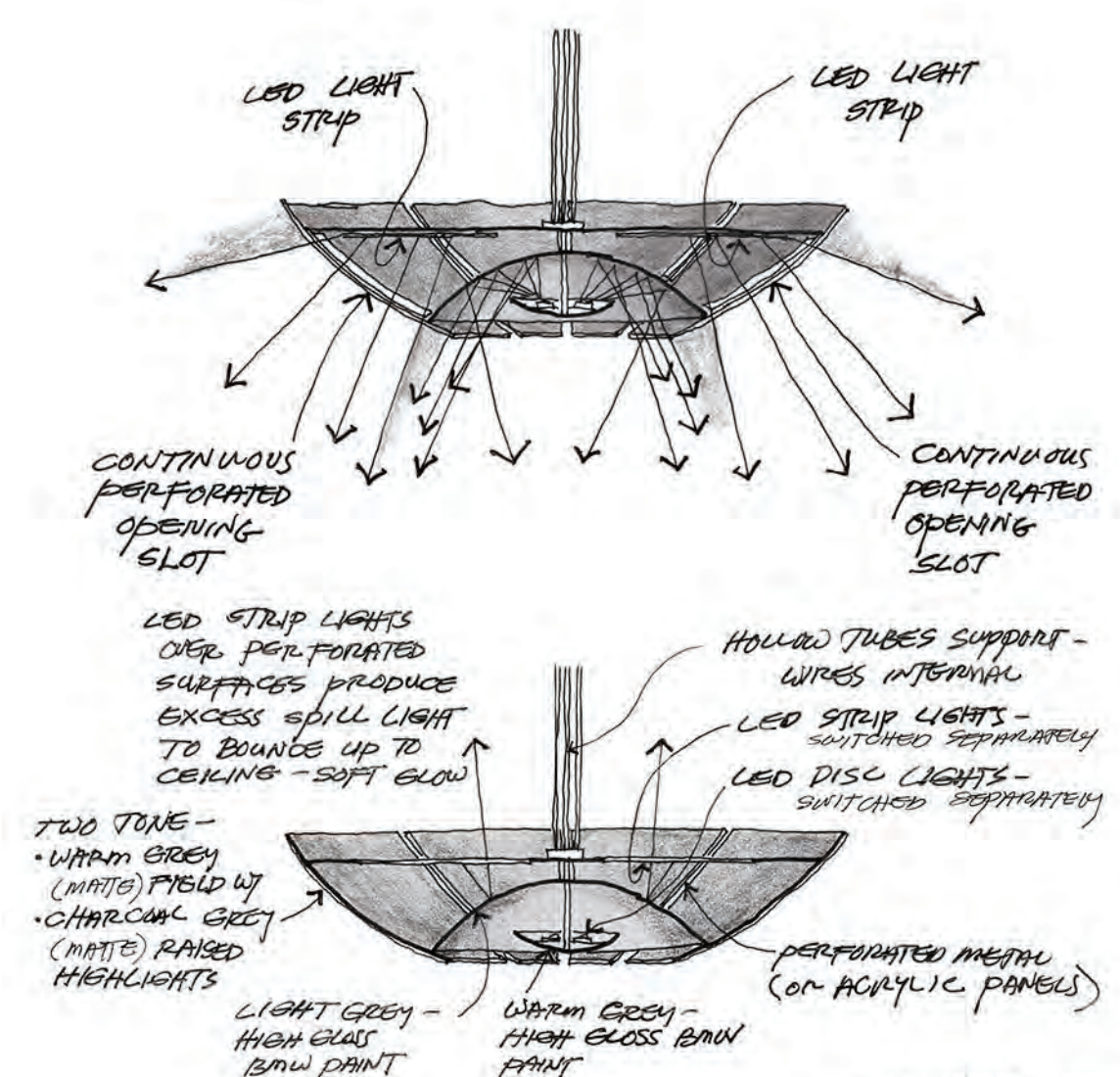



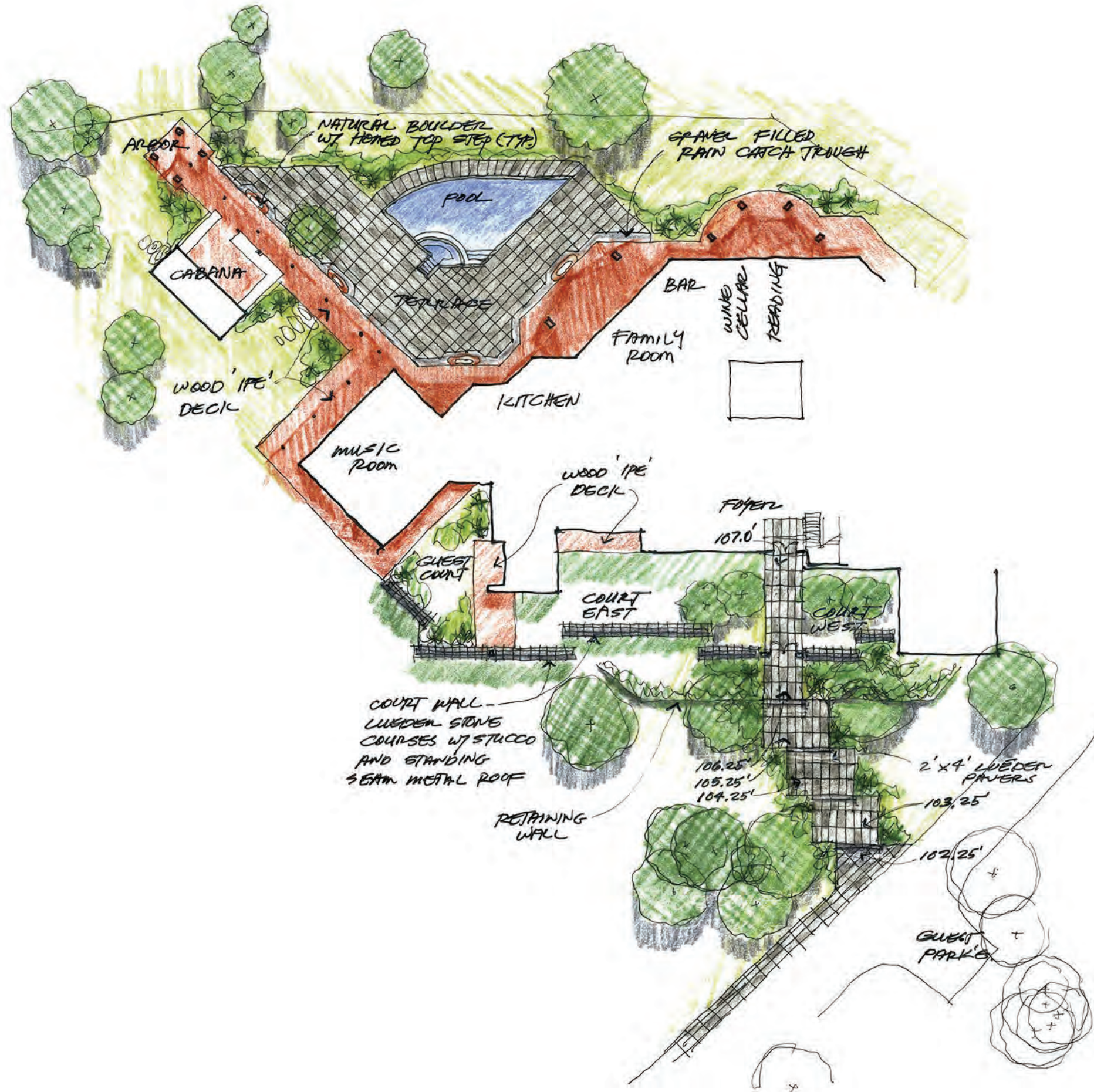

COURT WALL -  
 LUEDER STONE  
 COURSES W/ STUCCO  
 AND STANDING  
 SEAM METAL ROOF

RETAINING  
 WALL

GUEST  
 PARKING



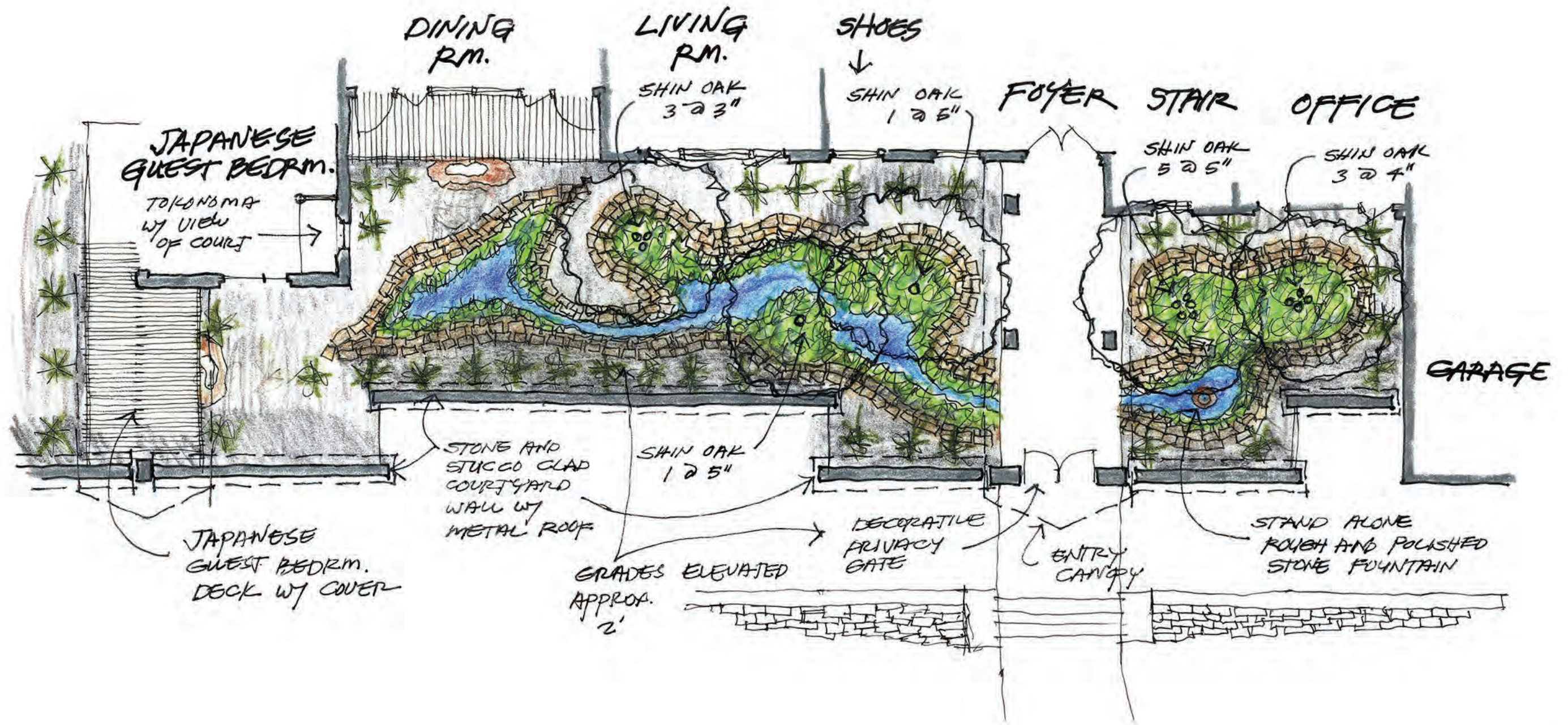



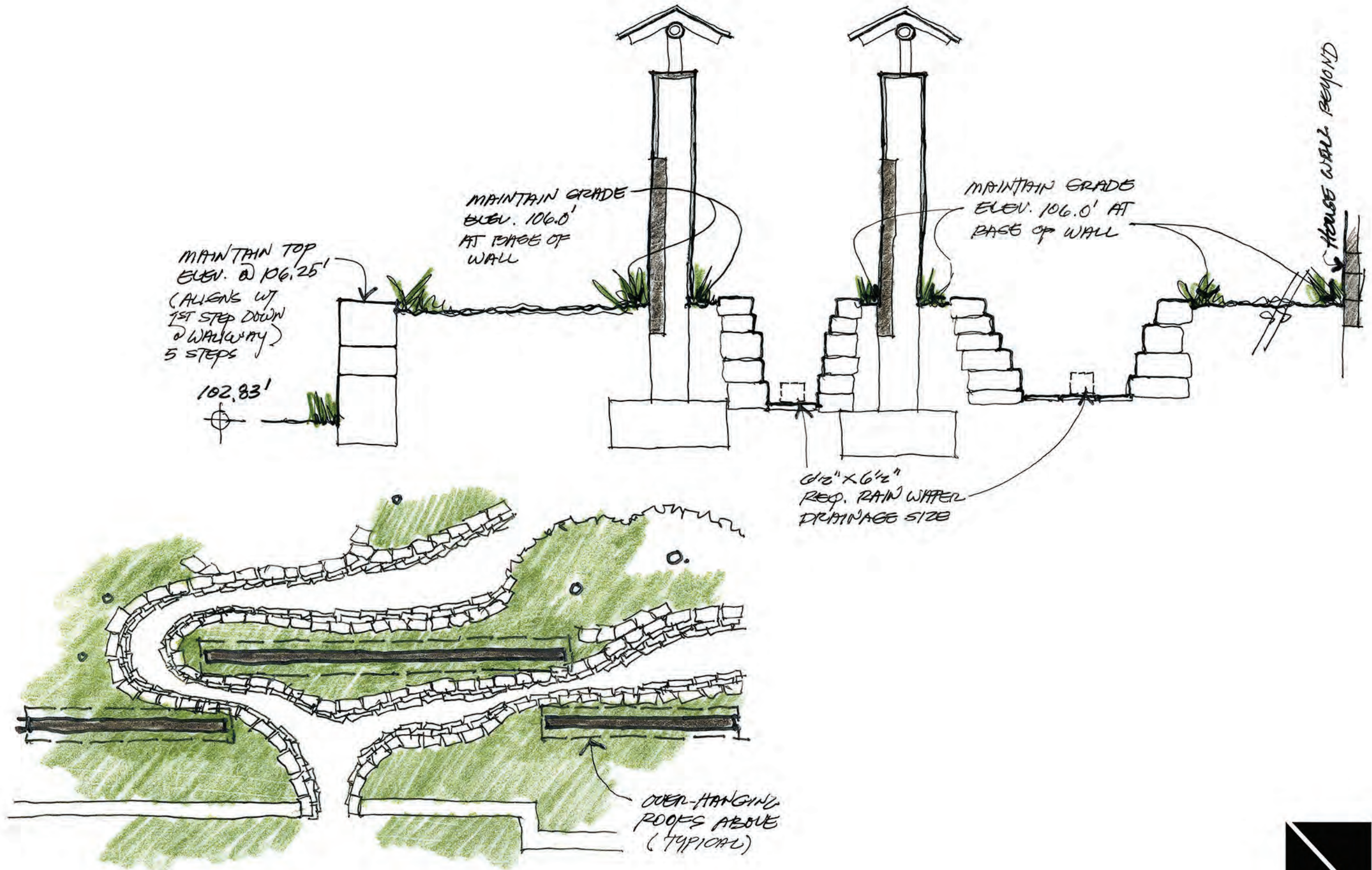



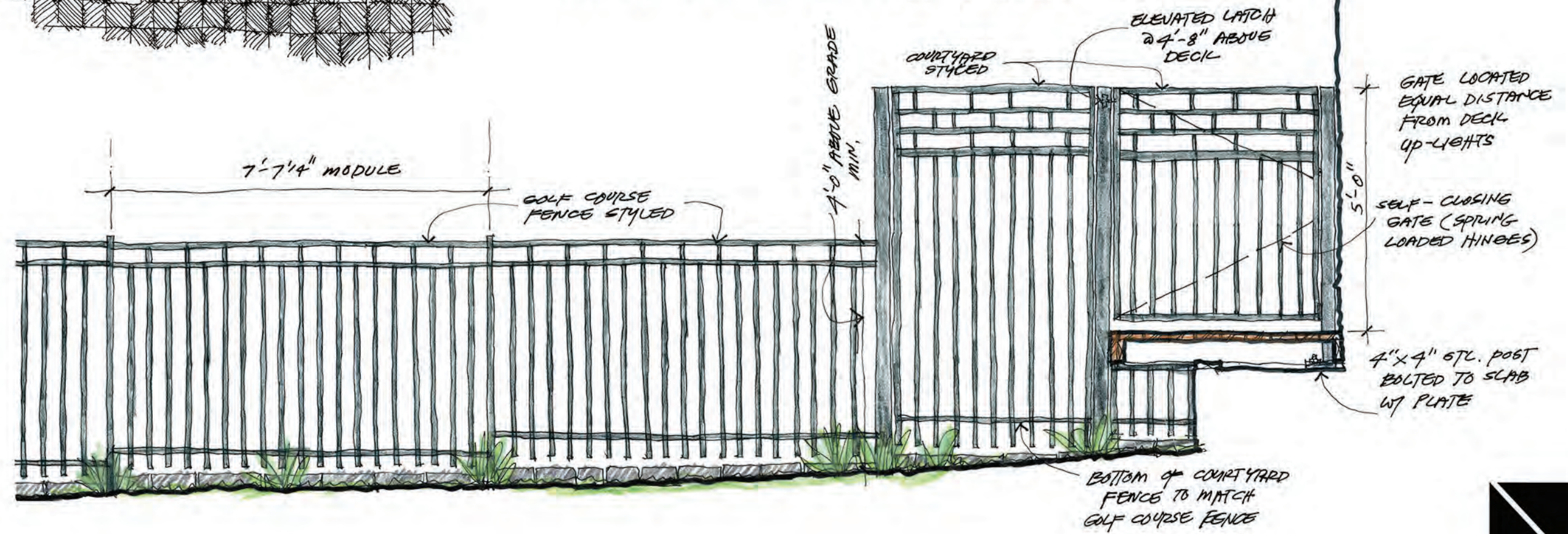
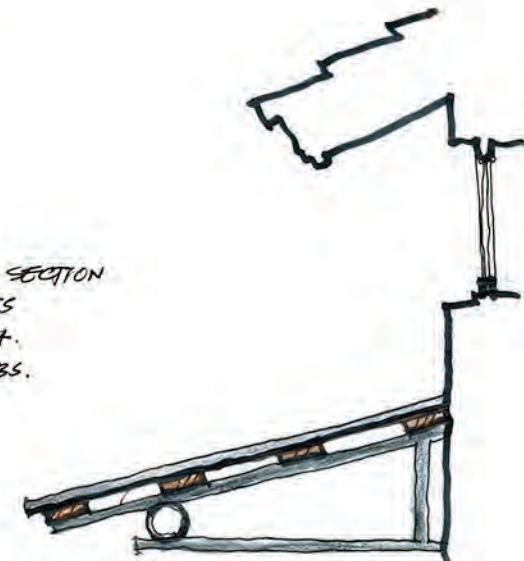
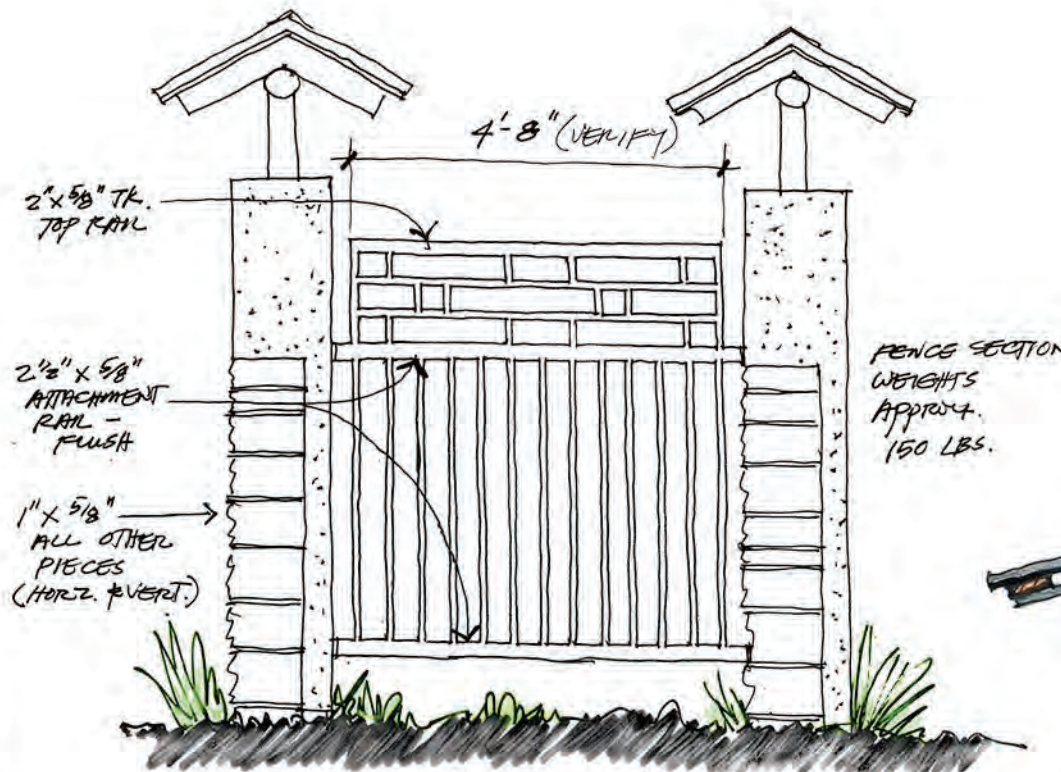
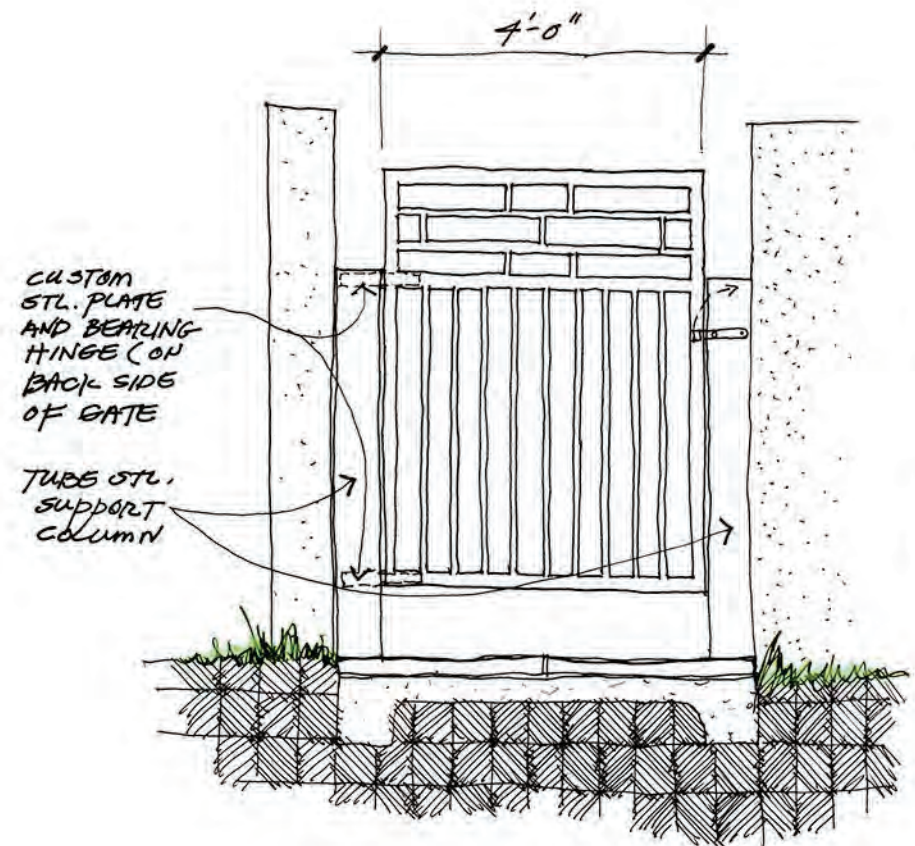



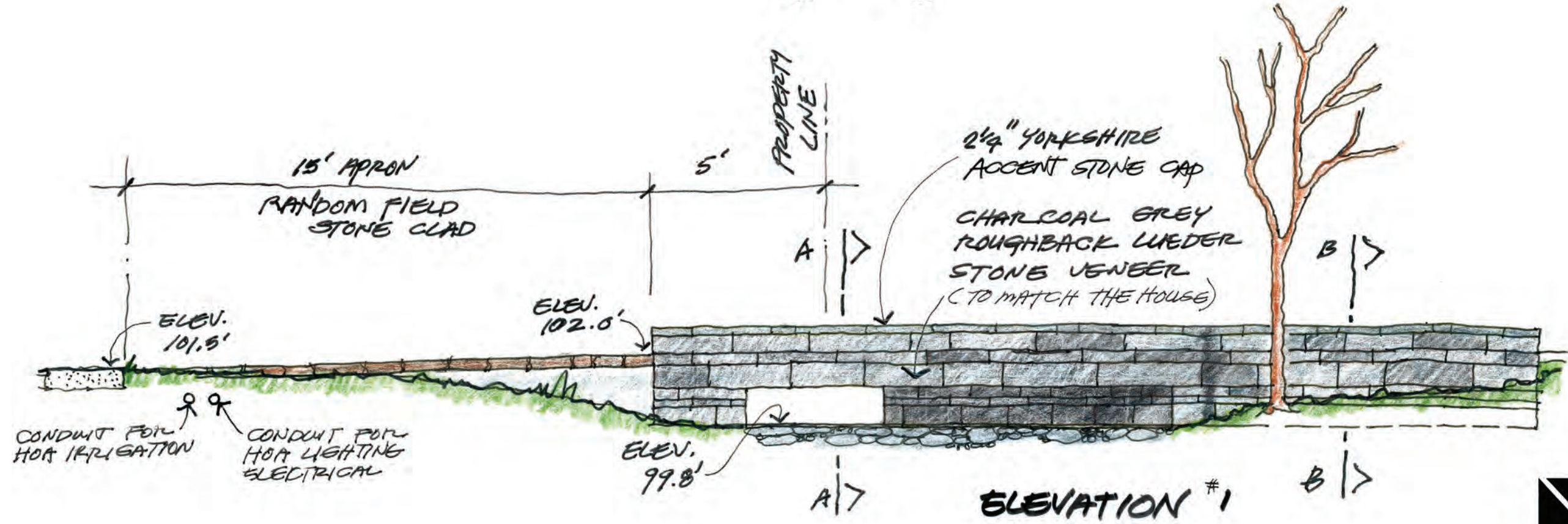
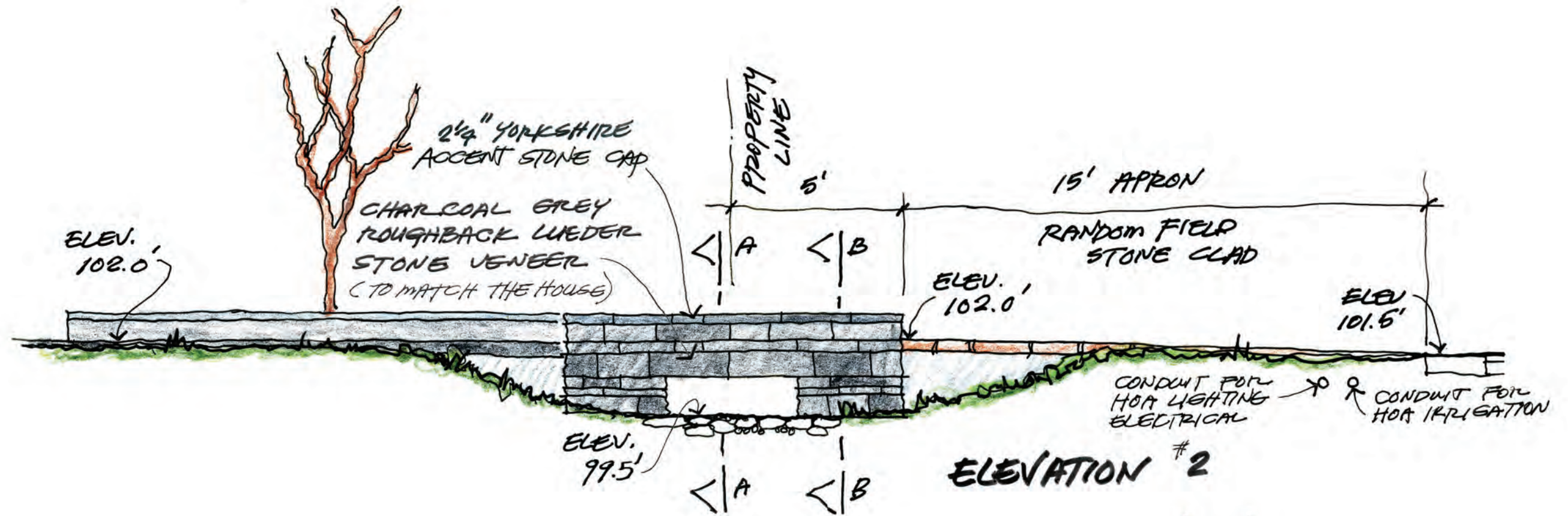



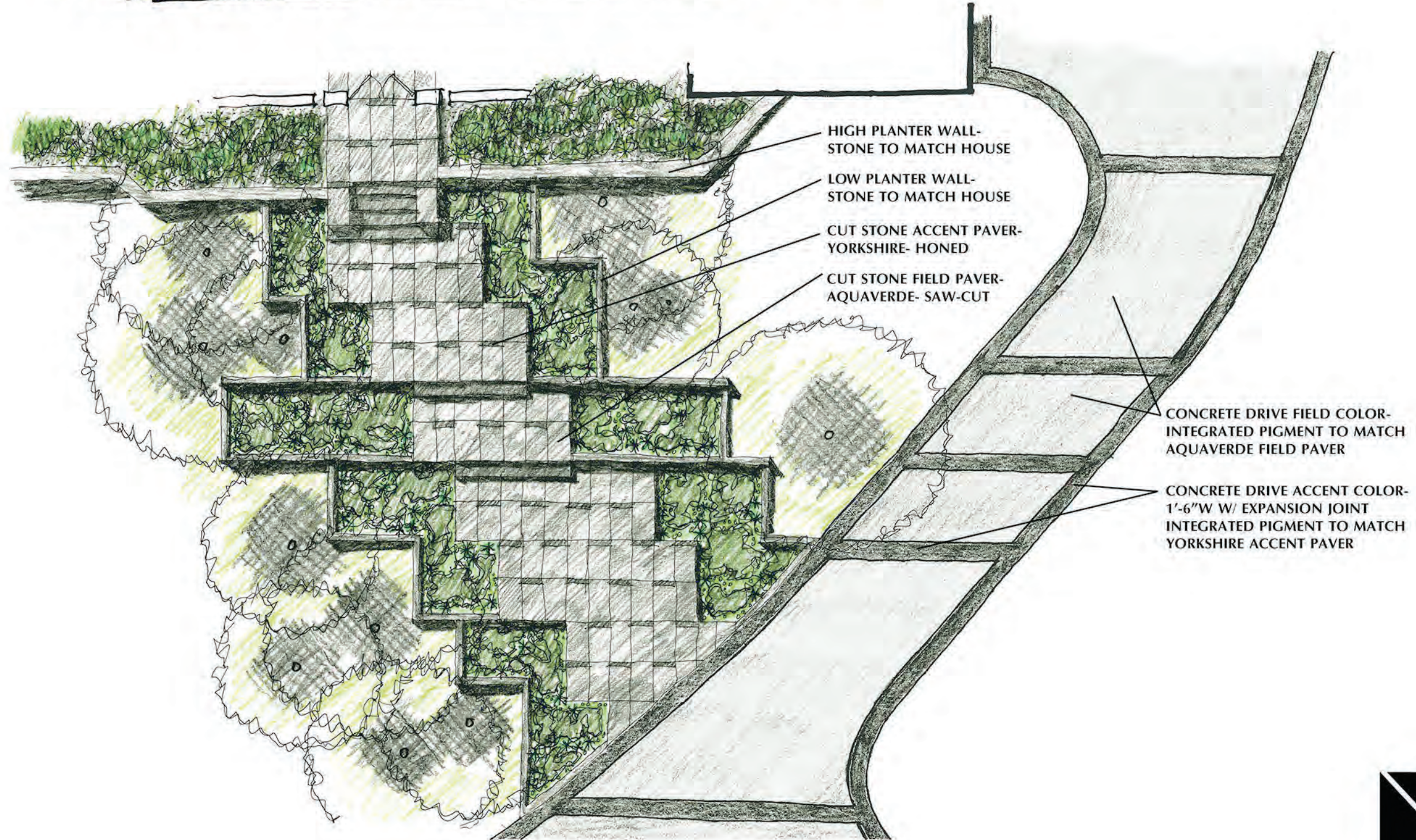
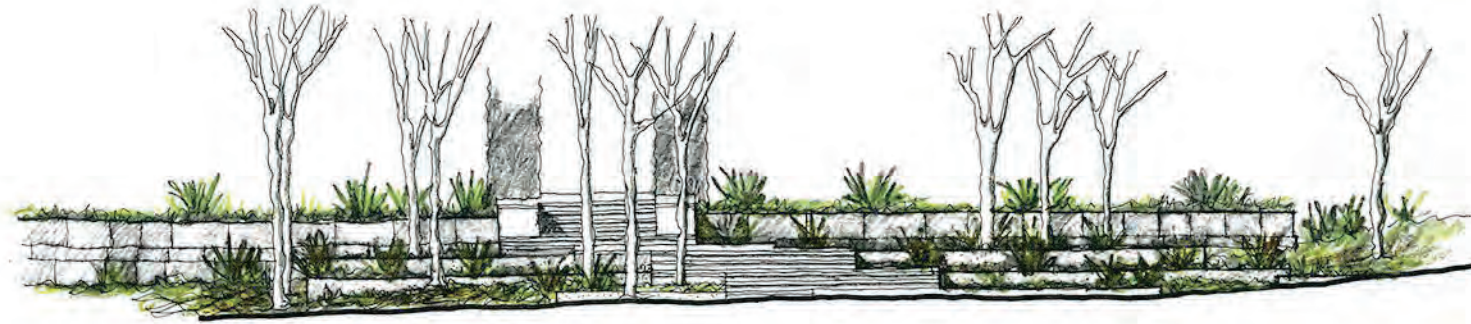



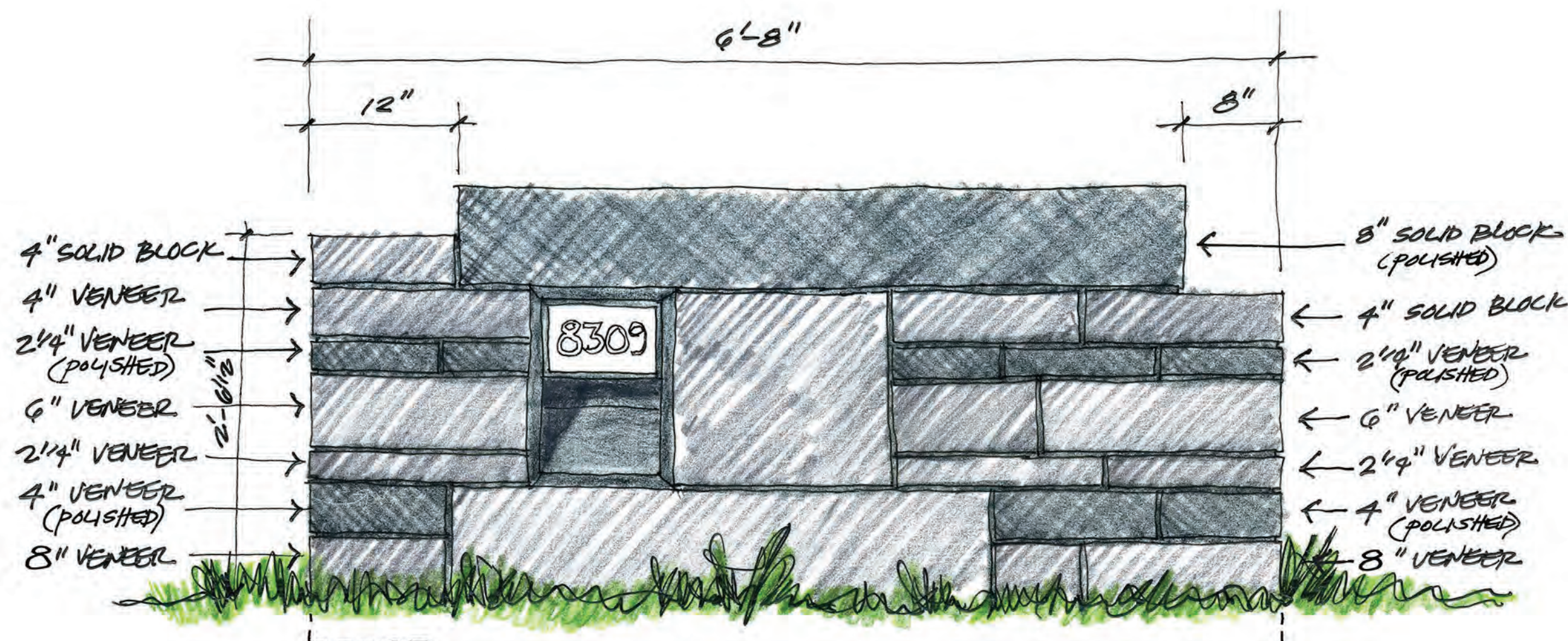

- ADDRESS LIGHT - RECESSED
- TWO HILLS STUDIO OF AUSTIN
  - MODEL RAL 1
  - DARKENED COPPER
  - AMBER IRIDESCENT GLASS
  - LED
  - GARAMOND FONT

\* ALL POLISHED SURFACES ARE "YORKSHIRE"  
 \* ALL SURFACES ROUGHBACK UNLESS NOTED OTHERWISE



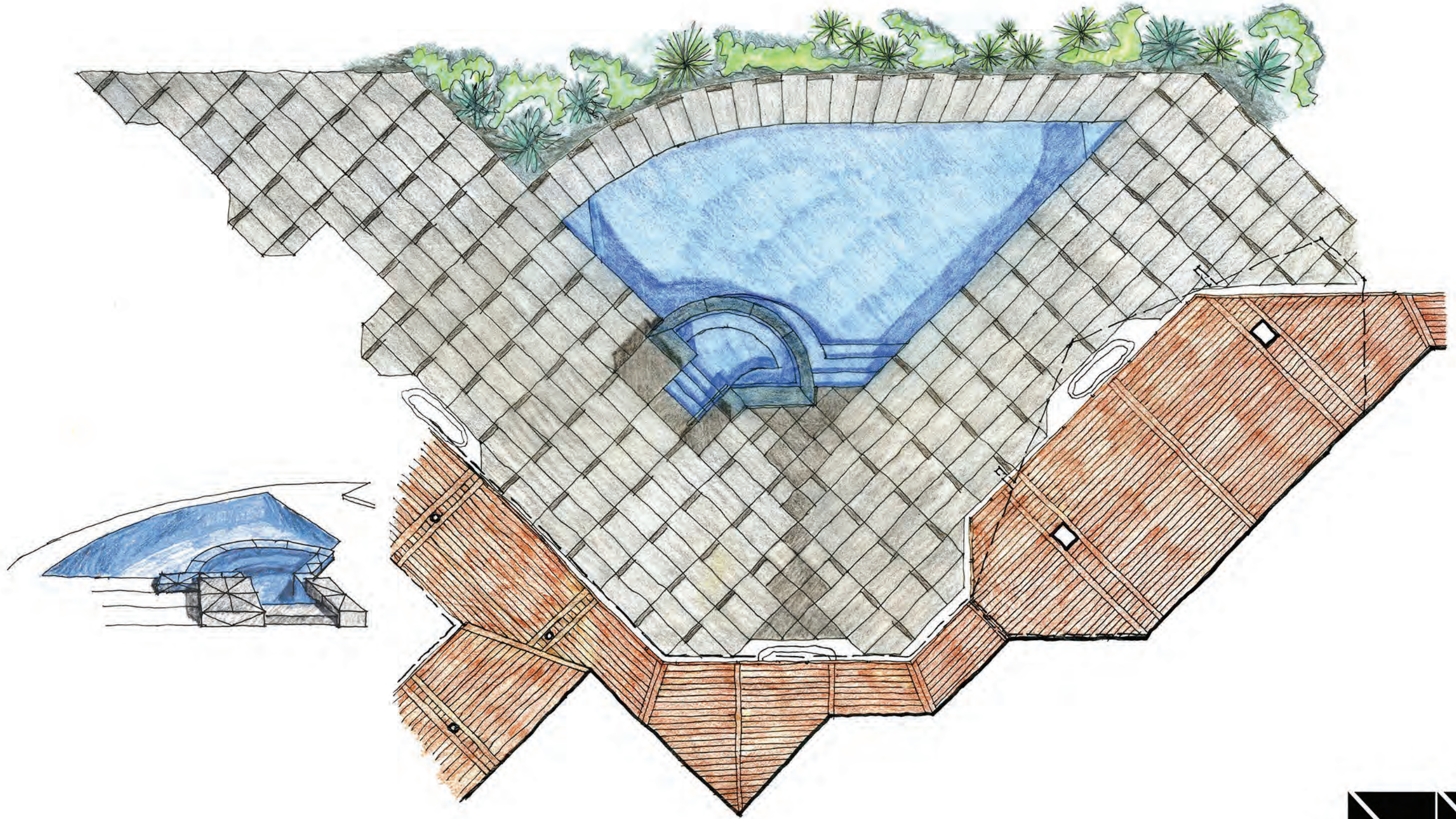



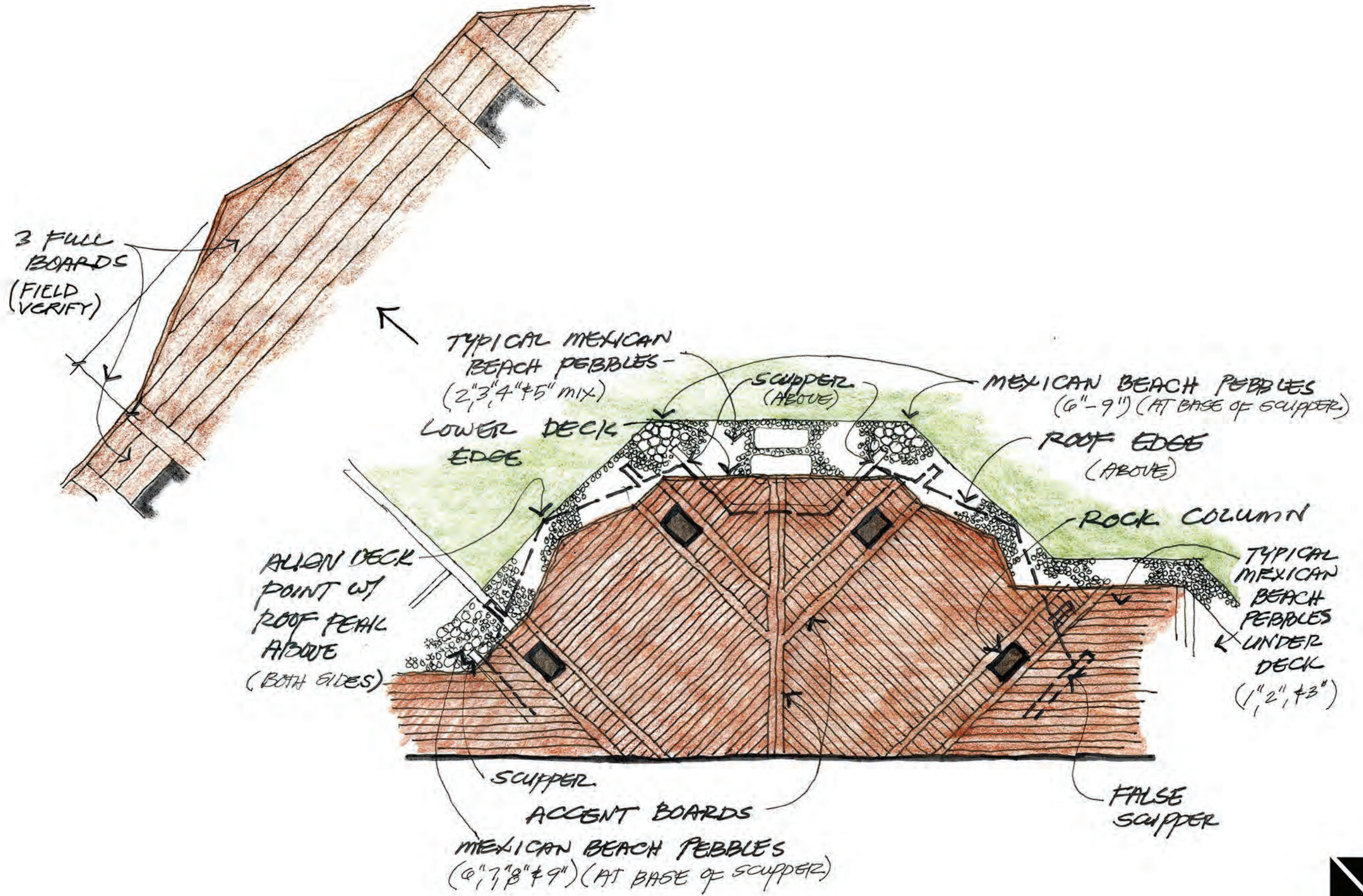



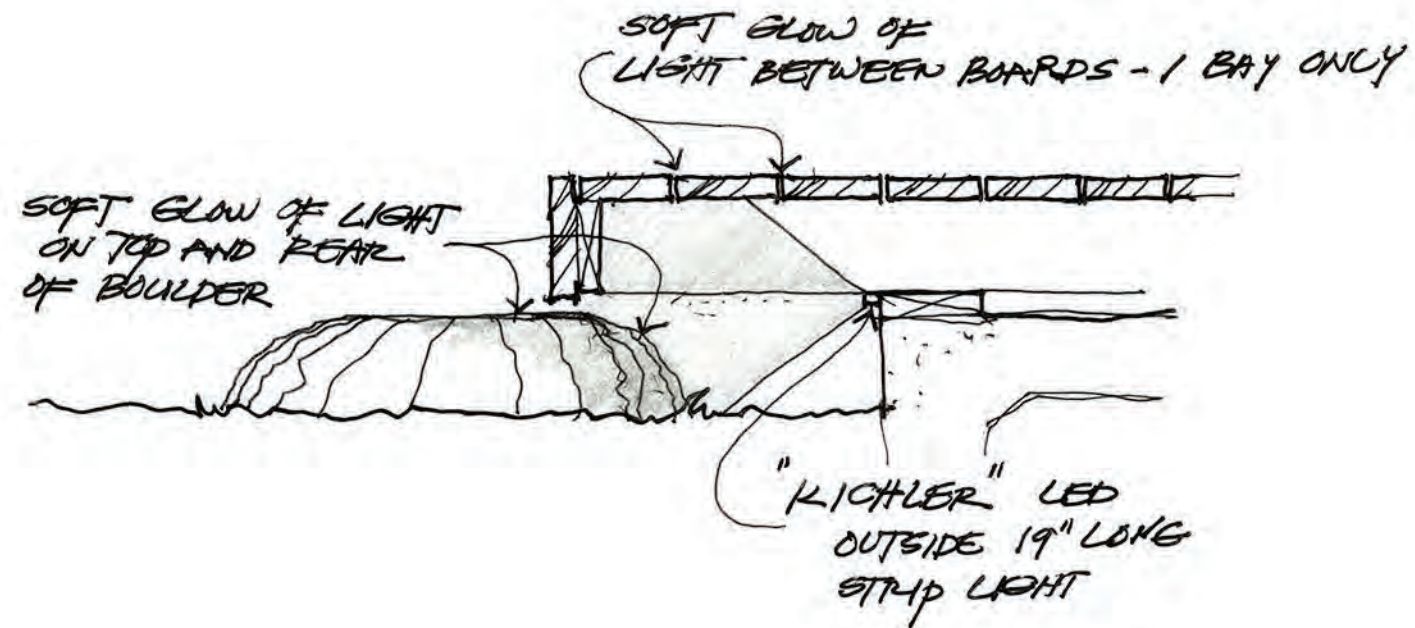
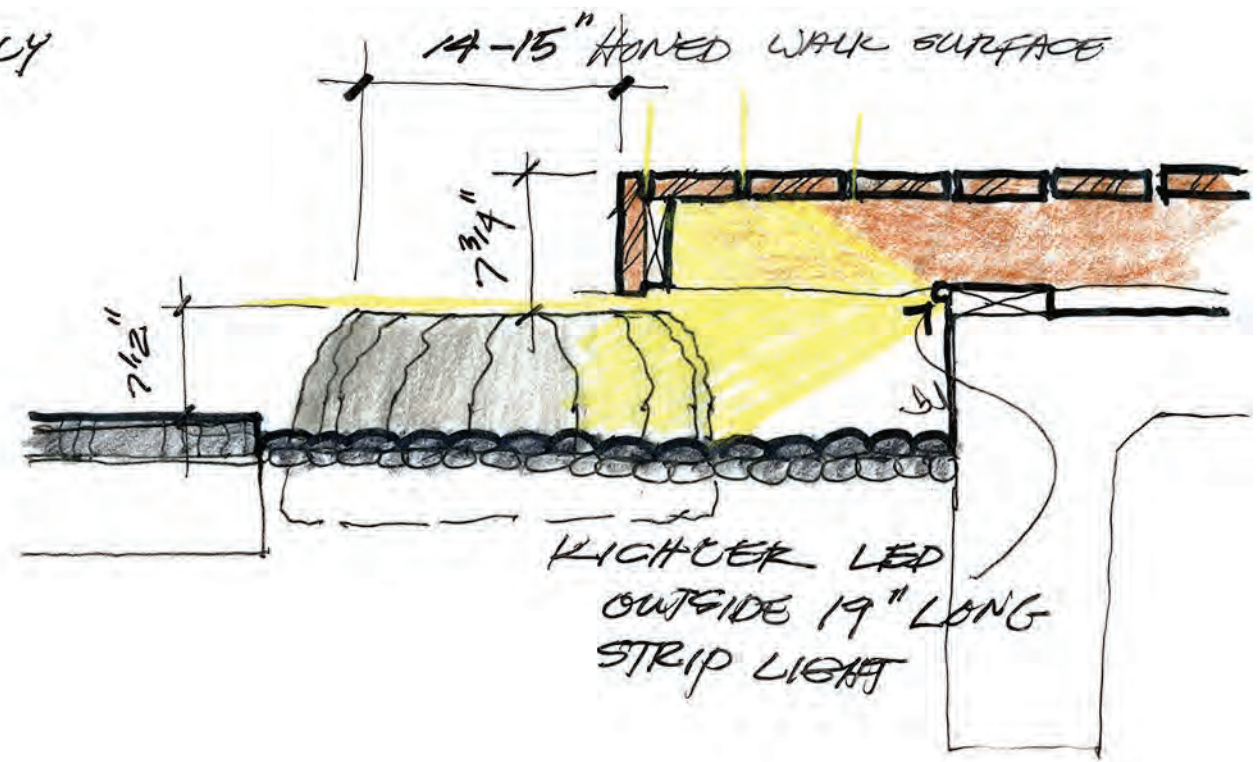
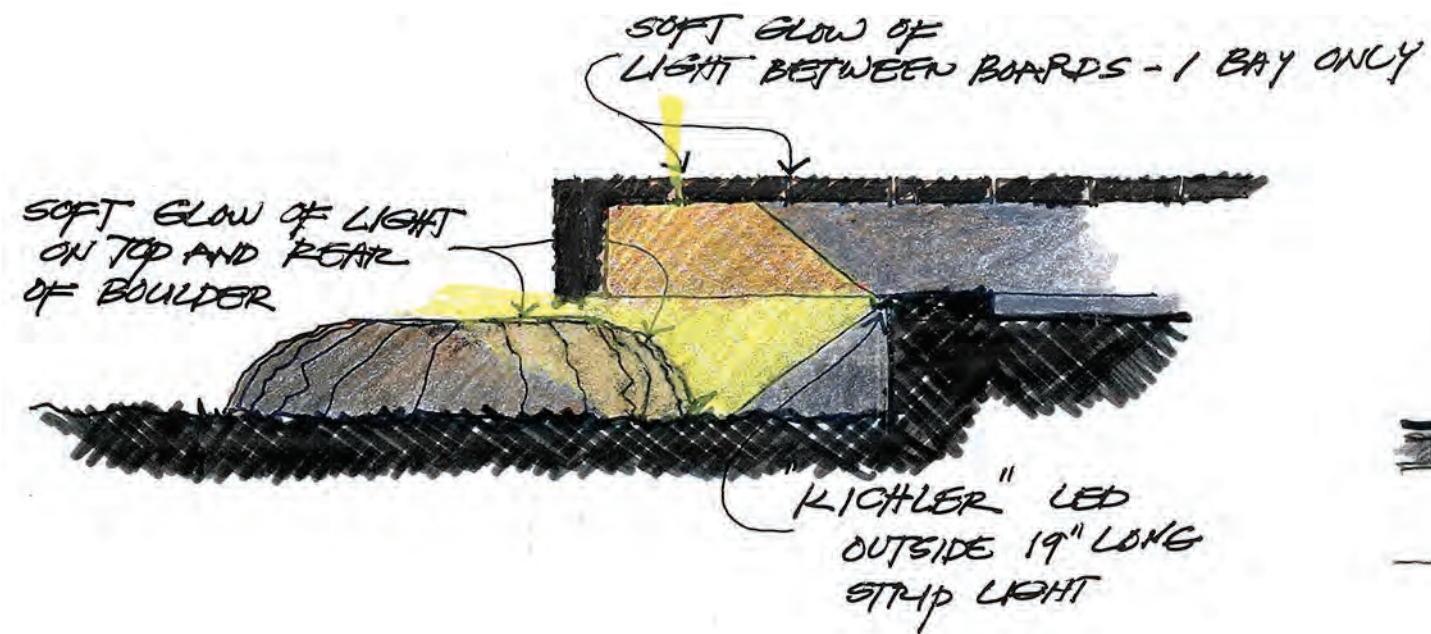



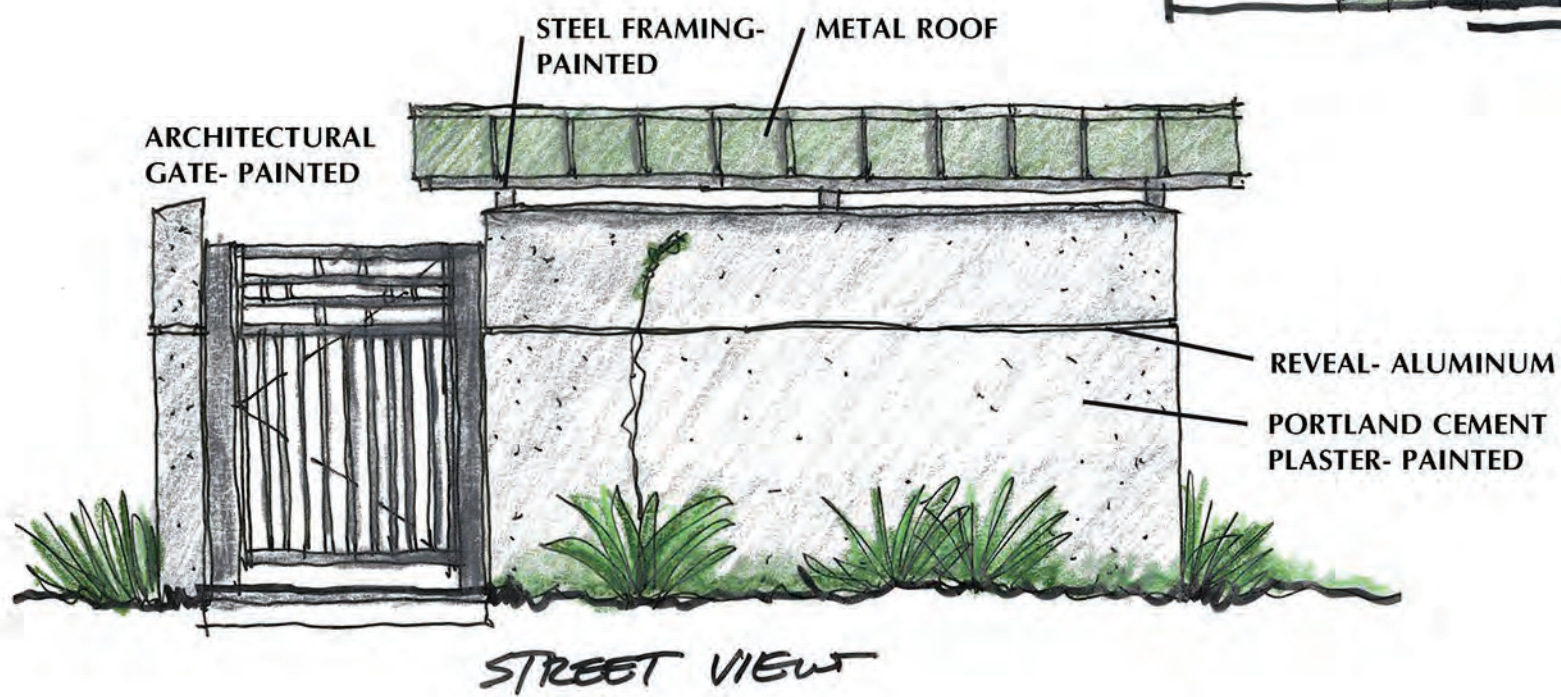
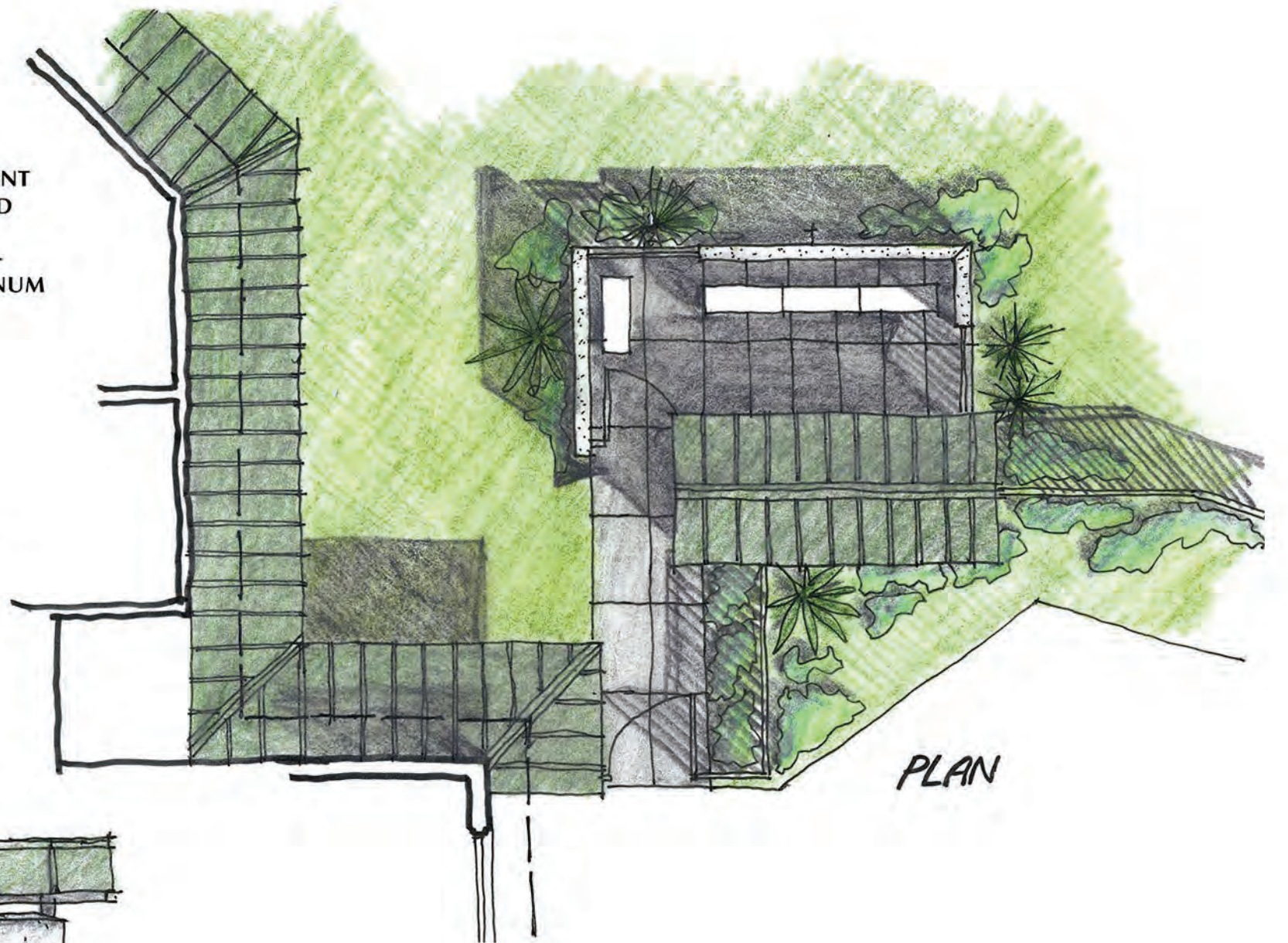
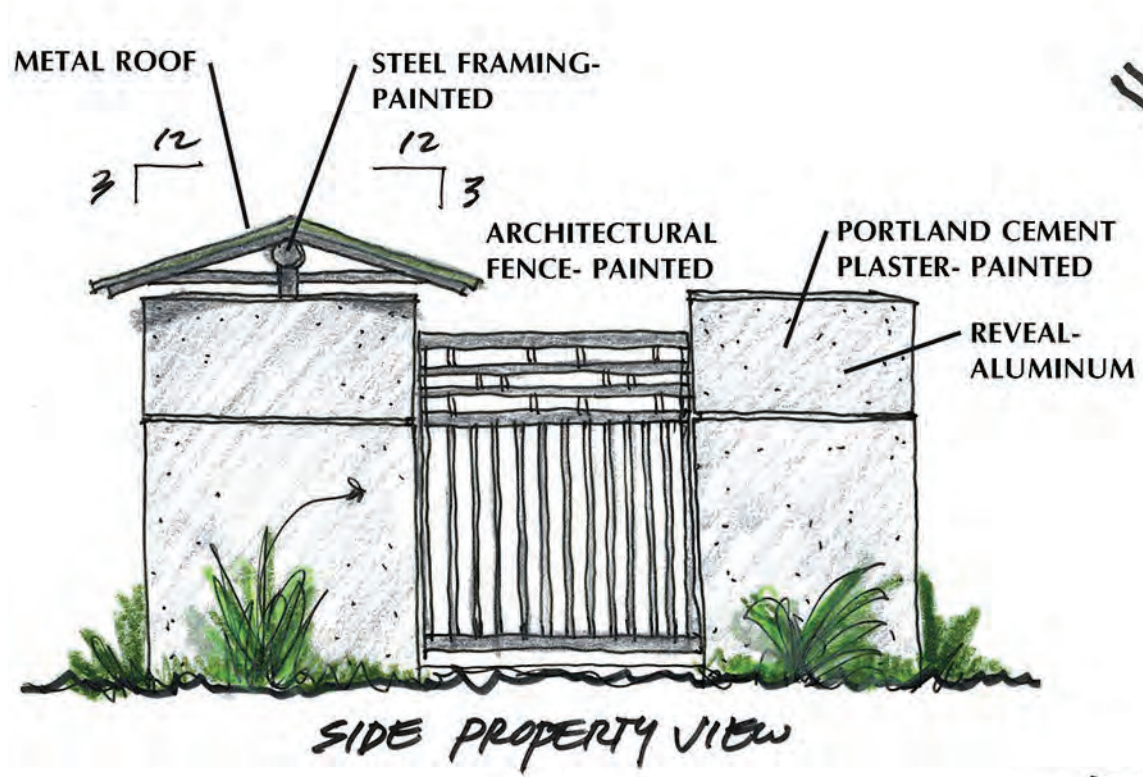



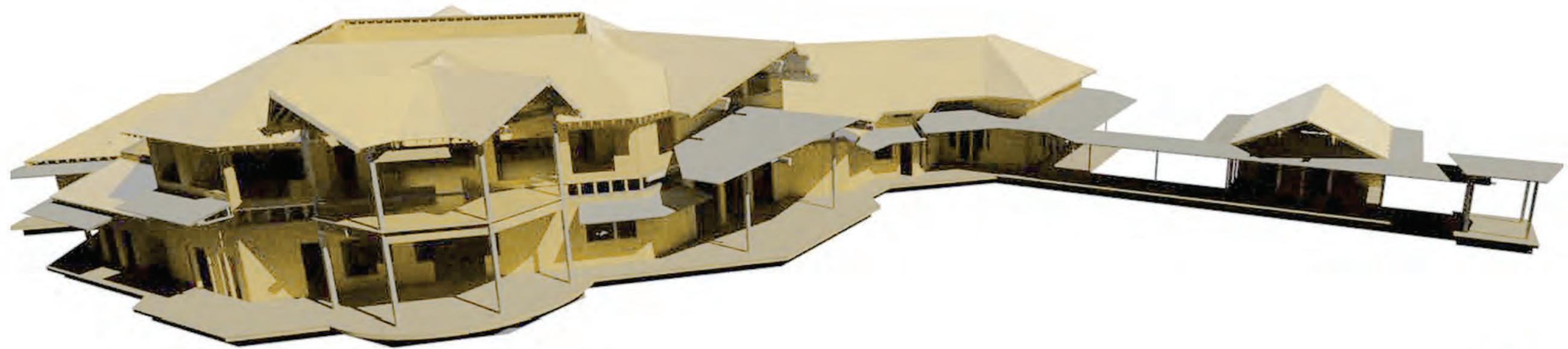

NIX GROUP  
ARCHITECTS



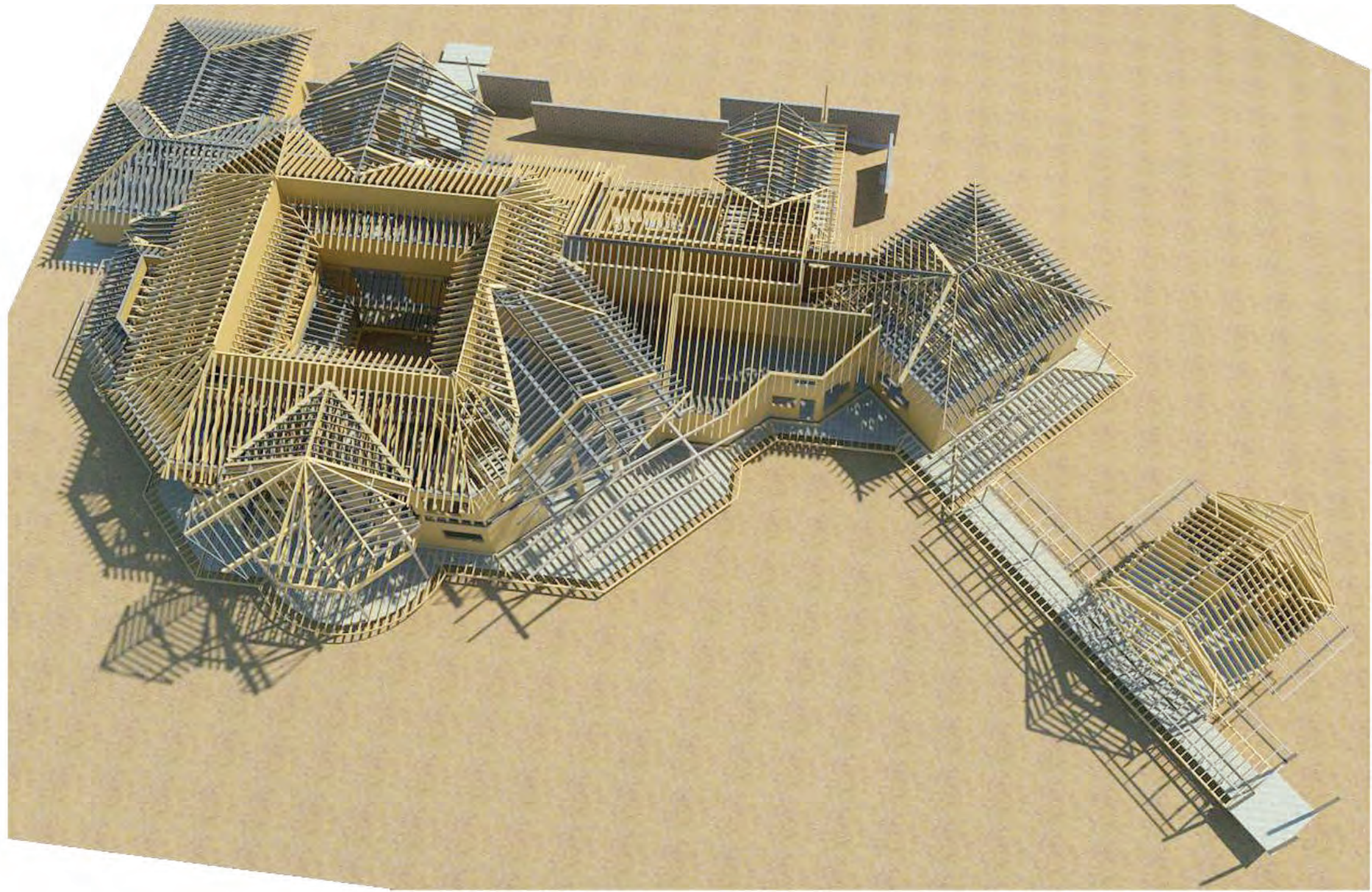

NIX GROUP  
ARCHITECTS



